

Accessories

Connector ASA Series



Description

The asa universal connector is a patented system that offers many possibilities regarding dimension and direction of the hydraulic connection.

With each connector you can choose from 3 directions how to install it into the hydraulic circuit. The stream optimized design reduces the total pressure drop on the cooler. The omission of screwed joints reduces the number of sealing surfaces. The available connector dimensions depend on the cooler size and are shown in the table below.

Our newest option is an intermediate plate for having an additional BSP 1/2" port, which can also be turned in any required direction.

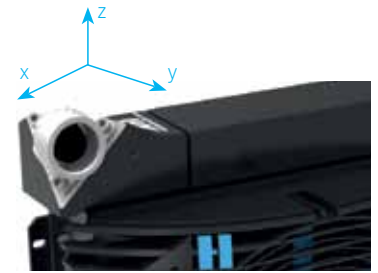

Dimensions

AUC NG 32 – 40 Connectors

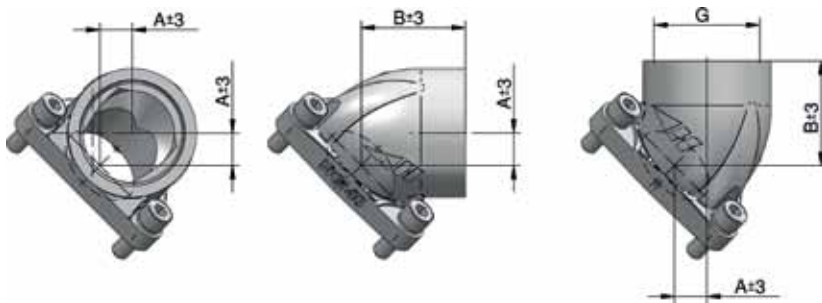

Intermediate plate NG 40

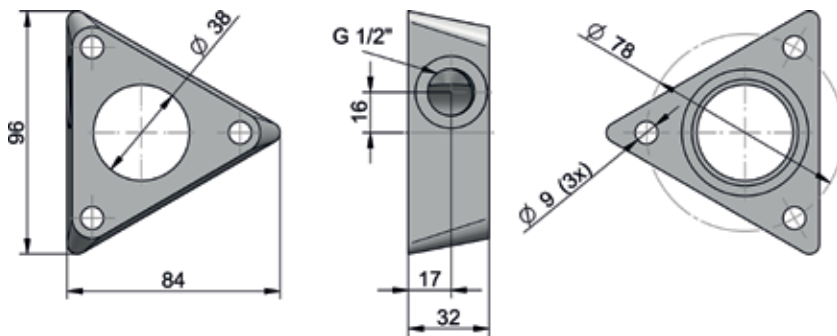

Technical Data

order number	description	A	B	G	connector material	o-ring	weight
		[mm]	[mm]				[kg]
ILLZASA32G32	AUC NG 32 – G 1 1/4"	14	34	BSP 1 1/4"	aluminum	NBR, 70 shore, 44 x 3 mm	0,31
ILLZASA40G40	AUC NG 40 – G 1 1/2"	15	47	BSP 1 1/2"			0,29
ILLZASA32U20	AUC NG 32 – UN 15/8"	14	34	UN 15/8"			0,31
ILLZASA40U24	AUC NG 40 – UN 17/8"	15	47	UN 17/8"			0,29
ILLZASA40-40G12	intermediate plate NG 40	-	-	-			0,30

Content (except intermediate plate)

asa universal connector	2x
o-ring	2x
screw	6x
spring ring	6x

requires 2 pcs per cooler



packed size, 2 pieces

Fits On Cooler Types

ILLZASA32G32	ASA 0177, 0257, 0367, 0467, 0567, 0727, 0927
ILLZASA40G40	ASA 0177, 0257, 0367, 0467, 0567, 0727, 0927

This data sheet and the corresponding scale drawings are to be used as a general guideline and technical overview of our products. Please contact us if more exact information is needed. As we are constantly improving our products, their characteristics, dimensions and weights may also change, although we do our best to incorporate these changes continually. asa assumes no liability for any information therein, any errors, omissions, misprints, nor any direct or indirect damages, losses or costs resulting therefrom. Any cooling performances and general technical values indicated in this catalogue are measured at a test bench according to asa testing procedures or calculated, based on such tests. Due to different conditions in testing and application environments the performance may also vary by +/- 15%. Because there is no standardized testing procedure, tests used by other manufacturers could have different results. Therefore we recommend all products to be checked under the system operating conditions. This is also true for vibrations and mechanical stress as well as for pressure peaks and thermal stress and any other relevant factors. General tolerances according to DIN ISO 2768-v. General tolerances for casted parts according to EN ISO 8062-3 (DCTG 10). Tolerances for rubber parts are according to ISO 3302-1 (class M4-F+C). The tolerances of welding seams are defined by quality group D according to EN ISO 10042, if it is not specified on the actual scale drawing or data sheet. In addition to that we point out that any data sheet and corresponding scale drawing is no substitution for the manual.