



ENAPART



93 S Railroad Avenue Unit C
Bergenfield NJ 07621 USA
www.enapart.com
sales@enapart.com



Via del Canneto 35,
Borgosatollo, Brescia - Italia
www.enapart.it
vendite@enapart.it



Barbaros Mah. Ihlamur Bul. Aĝaoĝlu
My Newwork No:3/15 Ataşehir / İstanbul
www.enapart.net
satis@enapart.net



PRIVADA 10 B SUR #3908 COL.
ANZUREZ, C.P. 72530, PUEBLA, PUE
www.enapart.com.mx
sales@enapart.com.mx



Friedrich-Ebert-Anlage 36, 60325
Frankfurt am Main, Germany
www.enapart.de
anfrage@enapart.de



4 boulevard Carnot, 95400
villiers-le-bel, Paris, France
www.enapart.fr
sales@enapart.fr



65049, ОДЕСА, ВУЛИЦЯ ІВАНА
ФРАНКА, БУДИНОК 55, ПОВЕРХ 3
www.enapart.com.ua
sales@enapart.com.ua



MUNICIPIUL BUCUREȘTI, SECTOR 3,
B-DUL BASARABIA, NR.250, CORP P+5
www.enapart.ro
sales@enapart.ro



〒584-0023 大阪府富田林市若松町
東2丁目2番16号
www.enapart.co.jp
sales@enapart.co.jp



PLAZA NUESTRA SEÑORA DE LAS
NIEVES 12 ,LOCAL ,50012,ZARAGOZA
www.enapart.es
ventas@enapart.es



Складова база „Онгъл“, Склад А2, п.к.
4006, гр. Пловдив, България
www.enapart.bg
sales@enapart.bg



3 Austin Mews, High Street, Hemel
Hempstead, HP1 3AF , United Kingdom
www.enapart.co.uk
sales@enapart.co.uk

**CURTISS -
WRIGHT**



JOYSTICK CONTROLLERS

FINGER OPERATED

Innovation In Motion

INNOVATION IN MOTION

The Penny & Giles range of finger operated joystick controllers have been developed for the smooth, precise control of critical functions in a variety of industrial applications where a Human-Machine Interface (HMI) is required. Available in one, two or three axis configurations, the finger operated range has a choice of six different models, with ergonomic handle styles to enable superb proportional control. Each model has a range of selectable options for the most comprehensive matching of the joystick to your application.

Features

- Potentiometric or Hall effect sensing
 - Single and multi-axis control
 - Low profile handles
- Most models protected to IP65 minimum above the panel
 - Choice of outputs and switches
- Choice of handles with additional functions
 - Standard connectors

Benefits

- Long life and maintenance-free operation
- Suited to a range of control functions
- Unintentional operation reduced
- Operation in demanding environments
- Enables user configuration for system safety
- Increased operator control
- Simple, error free installation



Ergonomic handles

This range has been developed with operator comfort in mind. By reducing the mental and physical effort required to operate your equipment, Penny & Giles joysticks can help to increase your productivity. The small single axis rockers and controllers require

minimal effort to move the handles, which are styled to fit comfortably with finger and thumb operation. The multi-axis controllers have a choice of handle styles that allow you to select additional functionality for operator controls, with push button switches for 'Person present' detection, or a third axis of proportional control. In addition, the JC400 model can be specified with a choice of three lever forces.

Selection Guide

Penny & Giles offers the widest choice of options to suit your application.



JC025 Page 6

- Single axis rocker
- Compact, low profile with a choice of rocker styles and outputs

JC030 Page 6

- Single axis rocker
- Compact, low profile with a choice of outputs



EMC Directive 89/336/EEC

The products detailed in this document are supplied as components for installation into an electrical apparatus or system. They are outside the scope of the EEC directive and will not be CE marked.



Certificate number LKQ 0924881

Quality Assurance
Penny & Giles are accredited to
BS EN ISO9001:2000

Quality is at the heart of all our systems ensuring the reliability of our products from initial design to final despatch.

JOYSTICK CONTROLLERS

FINGER OPERATED



Innovative design

The Penny+ Giles joystick range are displacement joysticks that provide electrical signals in direct proportion to the movement of the lever. Two different types of sensing technology are utilised in the finger operated controller range.

The JC025, JC030, JC100, JC120 and JC400 models use long life potentiometer tracks with directional/center switching, and the JC2000 model uses non-contact Hall effect sensors.

Potentiometric sensing

Designed to interface with an electronic controller, the long-life potentiometer tracks generate analogue outputs with switched reference signals that are proportional to the distance and direction over which the handle (or rocker) is moved. The analogue output can be factory configured to provide signals for fault detection circuits and a center tap provides an accurate voltage reference for the center position or a zero point for a bipolar supply voltage. An electrically independent switch operates with separate contacts each side of the joystick center position, in each available axis.

The key advantages of this technology are its linear output and the versatility it derives from its simplicity; it consists of a carbon-based potentiometer track with no complex circuitry or electronics, so it is not susceptible to electromagnetic interference or magnetic fields. However, as a contacting device it does have a long, but finite, life and due consideration should be given to applications subject to high intensity use or where high dither or vibration may be encountered.

Hall effect sensing

The JC2000 model uses non-contact Hall effect sensors to provide one, two or three axes of precision fingertip control, with dual independent outputs in the single and dual axis models for built-in redundancy and increased reliability. The key advantage of using Hall effect sensors is that they offer very long life because they have no contacting parts. They allow a very compact under-panel depth - as much as half the space of comparable potentiometer designs. Hall effect joysticks are more sensitive to electromagnetic interference, but this has been minimised by using appropriate shielding and robust circuit design for all but the most demanding environments.



JC100 Page 8

- Single axis joystick
- Low profile lever with a choice of outputs



JC120 Page 10

- Single axis joystick
- Lower profile lever with a choice of heights, outputs and protective boot
- Narrow width



JC400 Analogue Page 12
JC400 Digital Page 15

- Multi axis joystick
- Compact, minimal size with a wide range of mechanical and electrical options



JC2000 Page 22

- Multi axis contactless joystick
- Compact, minimal under-panel depth with a wide range of mechanical and electrical options

JOYSTICK CONTROLLERS

FINGER OPERATED



Total reliability

By using design innovation, careful materials selection and extensive real-life applications knowledge, Penny+ Giles engineers have developed a range of joystick controllers that require no maintenance throughout an expected working life of greater than five million operations (fifteen million operations for the JC2000). We also fit standard electronic connectors to the majority of our joysticks to help reduce both your installation time and the potential for wiring errors during your manufacturing process.

Safety

Joysticks fitted with the long-life potentiometer tracks can have additional resistors connected in series with the main resistive element to limit the output signals to 10-90% or 25-75%. This can be used as part of your systems comparison and error detection routine, where an out of range signal could indicate a wiring fault. Additional independent switch functions are provided for directional and center position indication - vital for system start-up safety. The JC2000 model uses Hall effect sensors and is supplied with dual independent outputs fitted as standard on the single and dual axis versions. The signals can be monitored and compared for failure detection in safety critical applications. See page 26 for application and usage notes on this model.



Custom design

Penny+ Giles offer an extensive range of finger operated joysticks in standard modular configurations, designed to meet the majority of individual customer needs, but we can customise our designs for OEMs who require something more specialised to their application. Please talk to our technical sales team about your requirements.

Cell manufactured

The modular design of the finger operated joystick range is intended to provide the user with the widest possible choice of standard options, but allows efficient build and despatch by using cellular manufacturing principles. Contact your nearest sales office for the latest information on availability of these joysticks.



RUGGED JOYSTICK CONTROLLERS HAND OPERATED

Penny+ Giles can also supply a range of hand operated joystick controllers for demanding operator control applications in off-highway vehicles and other Human-Machine Interfaces where ultimate strength, reliability and handle functionality are important.

PLEASE SEE OUR SEPARATE BROCHURES ON THE JC150 AND JC6000 MODELS



Typical operator controls on

- Aerial lifts, hoists and cranes
- Loaders, excavators and dozers
- Tractors and harvesters
- Telehandlers
- Forklifts

JC025 AND JC030

SINGLE AXIS ROCKER

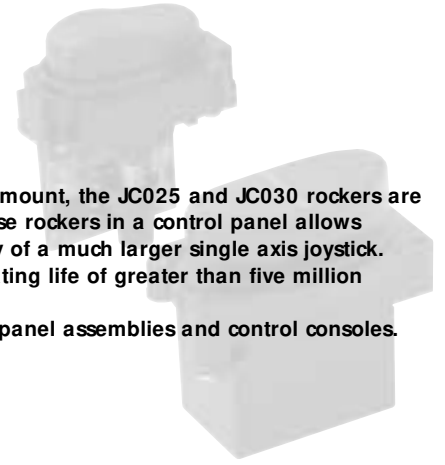

Developed for applications where compact size and minimal above panel height is paramount, the JC025 and JC030 rockers are very low profile whilst still providing precise fingertip control in one axis. The use of these rockers in a control panel allows designers to develop very low profile assemblies whilst still maintaining the functionality of a much larger single axis joystick. These rockers have been designed for maintenance-free operation throughout an operating life of greater than five million operations.

Typical applications include remote control chest packs, pendant controllers, low profile panel assemblies and control consoles.

PERFORMANCE MECHANICAL

Breakout force	N	5*	
Operating force	N	15*	Full deflection
Maximum allowable force	N	50*	Full deflection
Rocker operating angle	°	± 10	
Rocker action		Self centering	
Expected life (operations)		> 5 million	
Weight	g	30	

*14mm radius from center

ENVIRONMENTAL

Operating temperature	°C	-25 to + 70
Storage temperature	°C	-40 to + 80
Environmental protection		
JC025		IP65 (when correctly panel sealed) IEC 60529
JC030		IP60 (when correctly panel sealed) IEC 60529

Units supplied with O ring seal

ELECTRICAL

Analogue Track

Resolution		Virtually infinite
Track resistance (± 20%)	kΩ	1.8, 2, 2.9 or 5
Track electrical angle	°	± 9
Output voltage range	%	0-100, 10-90 or 25-75 of input (± 2%)
Center tap voltage (no load)	%	48 - 52 of applied voltage
Center tap angle	°	1.5 either side of center
Supply voltage - maximum	Vdc	22
Wiper circuit impedance	MΩ	Greater than 0.1**
Power dissipation @ 25°C	W	0.25 (no load)

** The long life resistive elements require a high impedance load in the wiper circuit to minimise the current flowing through the wiper for optimum conditions

Switch -

Directional or Center Off

Switch operating angle	°	2.5 either side of center
Supply voltage - maximum	Vdc	35
Load current - maximum	mA	5 resistive (or 200 with reduced switch life of 1 million operations)

ORDERING CODES

JC025 - - - BLK

Track resistance
N = 1.8k 0-100%
E = 5k 0-100%
R = 2k 10-90%
Q = 2.9k 25-75%

Rocker profile
STD = standard
V00 = V profile

JC030 - - V00 - BLK

Track resistance

No option on rocker profile for JC030

N = 1.8k 0-100%

E = 5k 0-100%

R = 2k 10-90%

Q = 2.9k 25-75%

DIMENSIONS AND MOUNTING OPTIONS

JC025

It is recommended that the JC025 is fitted from the back of the mounting panel using four M3 x 6mm female, self-clinching stand-offs (e.g. PEM ref. CSS M3-6) fitted to the back of the panel at opposite positions. The stand-offs are used in conjunction with four M3 x 6mm pan head screws. The panel cut-out and centers for the stand-offs are as shown in the panel mounting detail below.

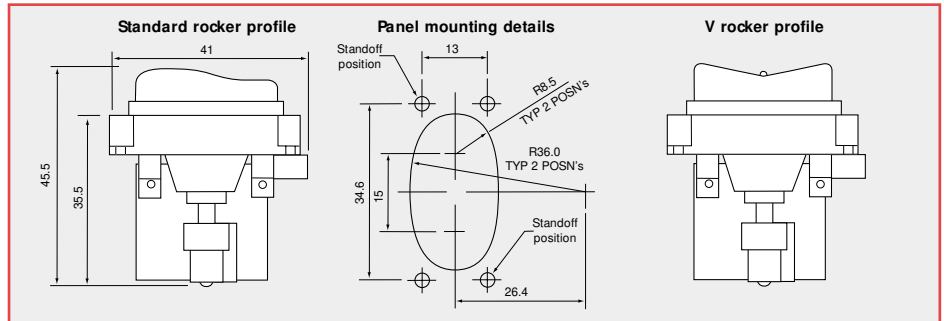

The recommended panel thickness is 3mm. The O ring supplied must be used to seal the JC025 rocker assembly to the mounting panel to enable IP65 protection.

JC030 - V profile only

It is recommended that the JC030 is fitted from the back of the mounting panel using four thread forming screws (supplied). Tighten the screws until initial contact with the body occurs ensuring body/flange relationship is square and flat. Continue tightening in 1/4 turn increments until a torque of 0.1 - 0.15Nm is achieved. The panel cut-out and centers are as shown below.

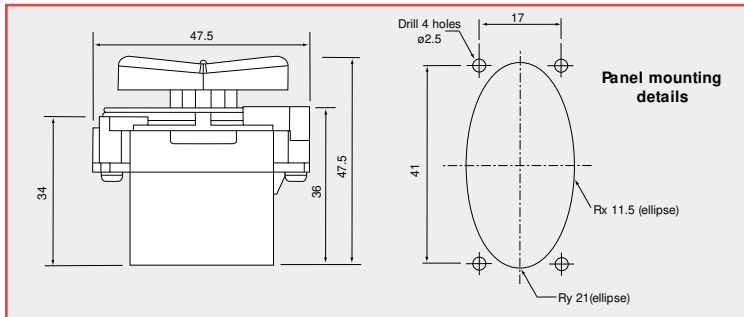

The recommended panel thickness is 3mm. The O ring supplied must be used to seal the JC030 rocker assembly to the mounting panel to enable IP60 protection. Supplied with 4 x panhead Pbzdrive self tapping screws for mounting to panel.

Penny+ Giles has designed the JC030 to meet IP60 rating, but it is the final responsibility of the customer to approve the product in its application.

ELECTRICAL CONNECTIONS

PTFE insulated 7/0.120 (28AWG) flying leads, 300mm long

Description

Positive voltage supply

Center tap

Negative or zero voltage supply

Output voltage signal

N/O switch, rocker backward

N/O switch, rocker forward

Common terminal for switch

Wire color

Pink/ Grey

Yellow/ Red

White/ Red

Pink

Green

Blue/ Orange

Black

JC100

SINGLE AXIS JOYSTICK

Developed for applications where ergonomics and system integrity are paramount, the JC100 is a compact, low profile joystick that provides smooth, precise fingertip control in one axis. The JC100 is sealed to IP66 to enable it to operate in extreme environments. With all the components contained within the handle, and standing only 70mm high, it is ideal for mounting in low profile panels and arm rests. Installation time has been reduced through the use of a standard electronic connector, and the joystick has been designed for maintenance-free operation throughout its operating life of greater than five million operations.

Typical applications include remote control chest packs and the control of construction, agricultural or material handling equipment.

PERFORMANCE MECHANICAL

Breakout force	N	2.3*
Operating force	N	3.4* Full deflection
Maximum allowable force	N	50* Full deflection
Lever operating angle	°	± 30
Lever action		Self centering
Expected life (operations)		> 5 million
Weight	g	45

*At top of handle

ENVIRONMENTAL

Operating temperature	°C	-25 to + 70
Storage temperature	°C	-40 to + 85
Environmental protection above flange		IP66† IEC 60529 Unit supplied with foam gasket seal

†Seal integrity can only be achieved when using sealing gasket supplied and screws are tightened to 0.7Nm. The installer should also ensure the mounting screws are adequately sealed.

ELECTRICAL

Analogue Track

Resolution		Virtually infinite
Track resistance (± 20%)	kΩ	4 or 5
Track electrical angle	°	± 28
Output voltage range	%	0-100, 10-90 or 25-75 of input (± 2%)
Center tap voltage (no load)	%	48 - 52 of applied voltage
Center tap angle	°	2.5 either side of center
Supply voltage - maximum	Vdc	32
Wiper circuit impedance	MΩ	Greater than 0.1**
Power dissipation @ 25°C	W	0.25 (no load)

** The long life resistive elements require a high impedance load in the wiper circuit to minimise the current flowing through the wiper for optimum conditions

Switch -

Directional or Center Off

Switch operating angle	°	5 either side of center
Supply voltage - maximum	Vdc	35
Load resistance - minimum	kΩ	10
Load current - maximum	mA	2 (resistive)
Typical contact resistance	Ω	150

ORDERING CODES

0-100% output voltage range, 4k
 10-90% output voltage range, 5k
 25-75% output voltage range, 5k

JC100-006
JC100-002
JC100-007

Mating connector kit

SA47269

DIMENSIONS AND MOUNTING OPTIONS

JC100

It is recommended that the JC100 joystick is fitted from the top of the mounting panel using four M3 screws (not supplied). The panel cut-out and centers for the screw positions are as shown in the panel mounting detail below.

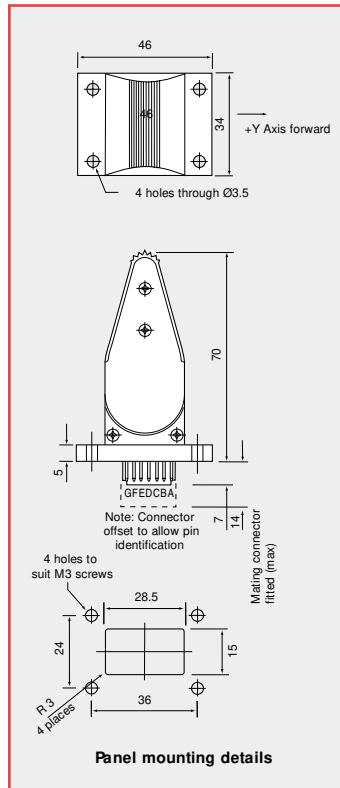

ELECTRICAL CONNECTIONS

Connection

Mating connector kit (order separately)

FCI DUBOX™ 7 way male connector (76382-307)

SA47269 (contains DUBOX™ 65240-007 female connector and 7 pins 76357-301

suitable for AWG 22-30 wire size). Requires crimping pliers (FCI No. HT234) to fit pins to wires.

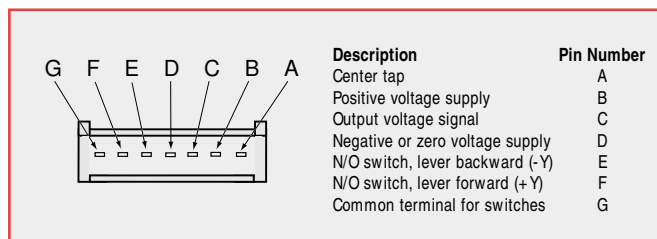

JC120

SINGLE AXIS JOYSTICK

Developed for applications where ergonomics and system integrity are paramount, the JC120 is a minimum width, low profile joystick that provides smooth, precise fingertip control in one axis with a choice of two lever lengths. The JC120 is sealed to IP66 to enable it to operate in extreme environments. Standing only 54 or 64mm high, the JC120 is less susceptible to unintentional operation. With all of the components contained within the handle, it is ideal for mounting in low profile panels and arm rests. Installation time has been reduced through the use of a standard electronic connector, and the joystick has been designed for maintenance-free operation throughout an operating life of greater than five million operations. An optional neoprene boot is available for the short handle version, allowing operation in environments where aggressive materials are present, protecting from dust and dirt ingress.

Typical applications include remote control chest packs and the control of construction, agricultural or material handling equipment.

PERFORMANCE

MECHANICAL

		Short handle	Short handle with boot	Long handle
Breakout force	N	3.1*	3.8*	2.3*
Operating force	N	5.1*	13.2*	3.4* Full deflection
Maximum allowable force	N	50*	50*	35* Full deflection
Lever operating angle	°	± 30	± 30	± 30 (or 0-60)
Lever action		Self centering	Self centering	Self centering or end return
Expected life (operations)		> 5 million	> 1 million for boot (replaceable)	> 5 million
Weight	g	45	47	45

*At top of handle

ENVIRONMENTAL

Operating temperature	°C	-25 to + 70
Storage temperature	°C	-40 to + 85
Environmental protection above flange		IP66† IEC 60529

† Seal integrity can only be achieved when using sealing gasket supplied and screws are tightened to 1Nm. Sealing gasket not required when neoprene boot is fitted to short handle version.

ELECTRICAL

Analogue Track

Resolution		Virtually infinite
Track resistance (± 20%)	kΩ	4 or 5
Track electrical angle	°	± 28
Output voltage range	%	0-100, 10-90 or 25-75 of input (± 2%)
Center tap voltage (no load)	%	48 - 52 of applied voltage
Center tap angle	°	2.5 either side of center
Supply voltage - maximum	Vdc	32
Wiper circuit impedance	MΩ	Greater than 0.1**
Power dissipation @ 20°C	W	0.25 (no load)

** The long life resistive elements require a high impedance load in the wiper circuit to minimise the current flowing through the wiper for optimum conditions

Switch - Directional or Center Off

Switch operating angle	°	5 either side of center
Supply voltage - maximum	Vdc	35
Load resistance - minimum	kΩ	10
Load current - maximum	mA	2 (resistive)
Typical contact resistance	Ω	150

ORDERING CODES

Short handle	0-100% output voltage range, 4k with boot fitted	JC120-0001
		JC120-0011
	10-90% output voltage range, 5k with boot fitted	JC120-0002
		JC120-0012
Long handle	25-75% output voltage range, 5k with boot fitted	JC120-0003
		JC120-0013
Long handle	0-100% output voltage range, 4k	JC120-0004
	10-90% output voltage range, 5k	JC120-0005
	25-75% output voltage range, 5k	JC120-0006
Long handle	0-100% output voltage range, 4k	JC120-0007
	With lever return to backward position	
	Ask for full specification details	
Mating connector	With 0.5m flyleads	SA301649
Neoprene boot	For short handle version only	P304856

DIMENSIONS AND MOUNTING OPTIONS

JC120

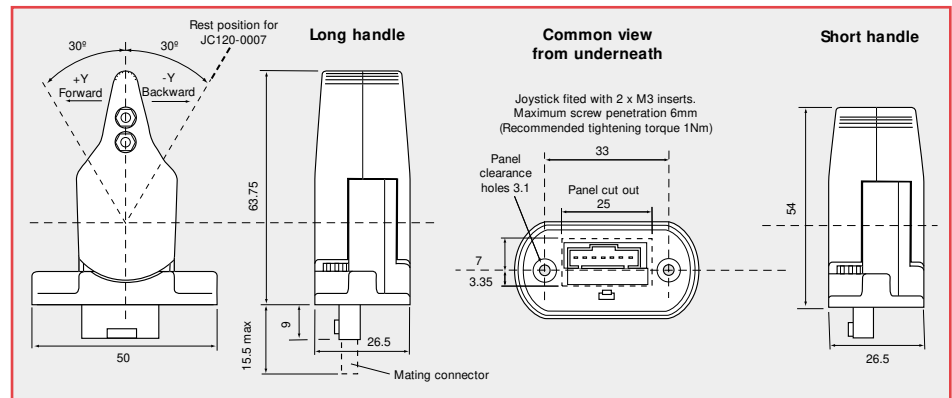

JC120 short handle - neoprene boot option

Recommended JC120 pitch spacing is 39mm minimum when neoprene boot is fitted

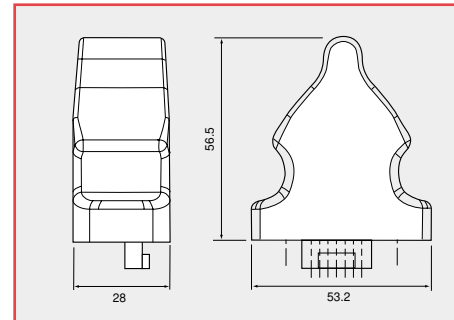

ELECTRICAL CONNECTIONS

Connection

Mating connector kit (order separately)

7 pin Molex series latching male (70553-0006)

SA301649 (7 pin Molex series latching female with 0.5m flyleads fitted)

	Description	Pin Number	Mating Connector/Flylead colour
A	Center tap	A	Orange
B	Positive voltage supply	B	Yellow
C	Output voltage signal	C	Green
D	Negative or zero voltage supply	D	Blue
E	N/O switch, lever backward (-Y)	E	Red
F	N/O switch, lever forward (+Y)	F	White
G	Common terminal for switches	G	Black

Pin A and E are not connected on JC 120-0007

JC400

MULTI AXIS JOYSTICK ANALOGUE OUTPUT

Developed for use in applications where compact size and functionality are important, the JC400 with analogue output offers proportional fingertip control in up to three axes. The JC400's range of ergonomic handles feature rotary operated potentiometers, or switches, for a third axis of control, or 'Person Present' switches that can be used to improve the integrity of your control system.

Installation flexibility has been provided by using different forms of mounting flanges independent of the function of the joystick and the analogue track models are supplied with side exit cables to minimize the required under panel depth. The joystick has been designed for maintenance-free operation throughout an operating life of greater than five million operations.

Typical applications include remote control chest packs, CCTV camera controls and the operator controls in construction, agricultural or material handling equipment.

PERFORMANCE MECHANICAL

Lever operating force		
breakout	N	2, 2.5 or 3*
operating	N	7.5, 11 or 12* (full deflection)
maximum allowable	N	250* (full deflection)
Lever mechanical angle	°	± 20 in X and Y directions
Lever action (options)		Self centering, aligned X and Y or non aligned
Lever gate profiles (options)		Single axis, square, round, diamond or cross
Expected life		> 5 million operations
Weight	g	150 nominal, without handle fitted *50mm above mounting flange face

ENVIRONMENTAL

Operating temperature	°C	-40 to + 70
Storage temperature	°C	-50 to + 85
Environmental protection above flange		IP65 IEC 60529

ELECTRICAL

Analogue Track

Resolution		Virtually infinite
Track resistance ± 20%	kΩ	4, 5 or 8
Track operating angle	°	± 16
Output voltage range	%	0-100, 10-90 or 25-75 of input (± 2%)
Center tap voltage (no load)	%	48 - 52 of applied voltage
Center tap angle	°	± 2.5
Supply voltage - maximum	Vdc	30
Wiper circuit impedance	MΩ	Greater than 0.1**
Power dissipation @ 20°C	W	0.25 (no load)

** The long life resistive elements require a high impedance load in the wiper circuit to minimise the current flowing through the wiper for optimum conditions

Switch -

Directional or Center Off/Center On†

Switch operating angle	°	5 either side of center (± 1)
Supply voltage - maximum	Vdc	30
Load current - maximum	mA	5 resistive (or 200 with reduced switch life of 1 million operations)

† The JC400 has an additional center on switch in each axis

DIMENSIONS

Note: drawings not to scale

INSTALLATION

The joystick is designed to be fitted from below the mounting panel, through a 37mm x 37mm square hole. The effectiveness of the joystick flange sealing is dependent on the panel mounting surface being sufficiently rigid to compress the sealing gaiter. The surface finish of the mounting panel is also critical to achieving an adequate seal and rough surface finishes, paint chips, deep scratches, etc. should be avoided.

Recommended panel thickness

3.5 to 6mm

Recommended screw torque

The JC400 joystick has three options for each mounting flange style, which include through holes and thread inserts in the 4mm diameter holes. To maintain an effective seal between the joystick flange and the mounting panel, the mounting screws should be tightened to a suitable torque to match the selected attachment screw size.

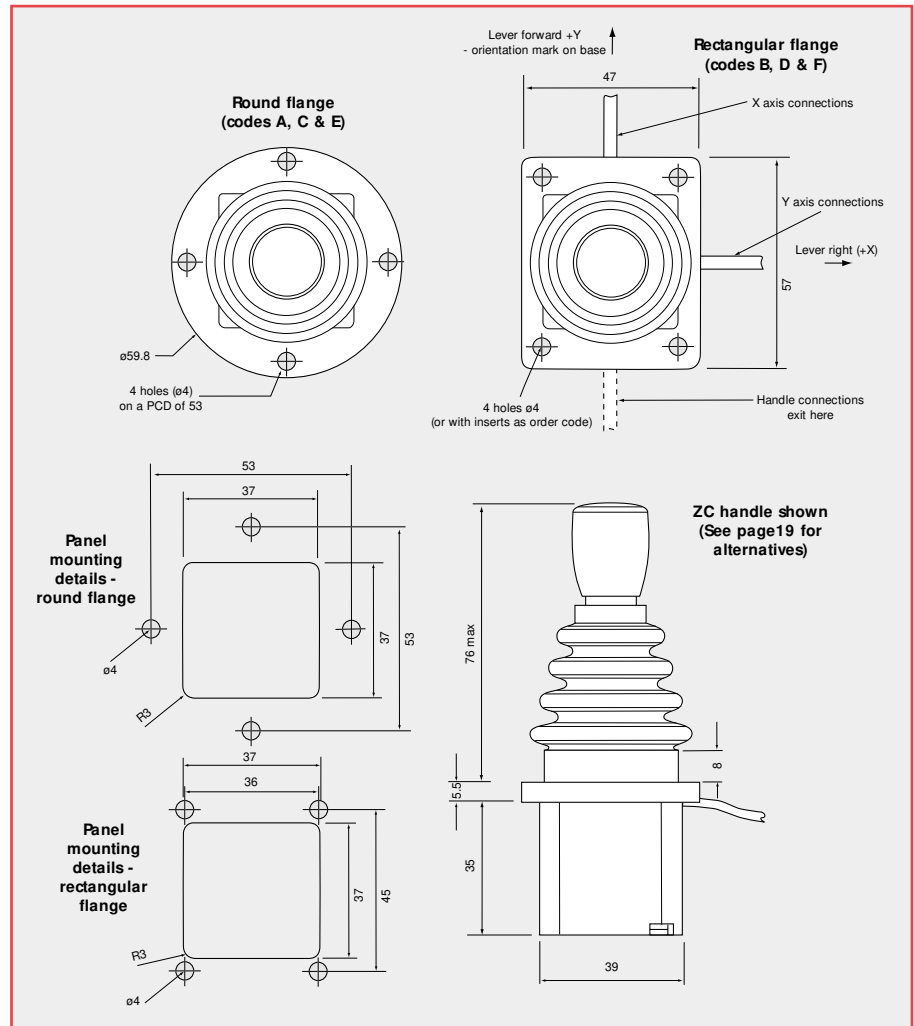

ELECTRICAL CONNECTIONS

PVC insulated 7/0.2 (24AWG) flying leads, 240mm long

Description

Y axis forward - positive voltage supply
 Y axis center tap
 Y axis backward - negative or zero voltage supply
 Y axis output voltage signal
 Y switch track N/O (lever forward + Y)
 Y switch track N/O (lever backward -Y)
 Y switch track center on
 Y switch track common

X axis right - positive voltage supply
 X axis center tap
 X axis left - negative or zero voltage supply
 X axis output voltage signal
 X switch track N/O (lever right + X)
 X switch track N/O (lever left -X)
 X switch track center on
 X switch track common

Flylead colour

Green
 Brown
 White
 Black
 Pink/Black
 Green/Red
 Red/Brown
 Yellow/Green

Orange
 Grey
 Red
 Yellow
 Orange/Black
 Red/Black
 Orange/Red
 Purple/Red

See over 
 for ordering information

JC400 ANALOGUE OUTPUT HOW TO SPECIFY

PERFORMANCE OPTIONS	FEATURE	CODE
MOUNTING FLANGE	Round flange, 59.8mm diameter with 4 x 4mm through holes	A
	Rectangular flange, 47 x 57mm with 4 x 4mm through holes	B
	Round, as code A, but with Metric thread inserts (M3 x 0.5p)	C
	Rectangular, as code B, but with Metric thread inserts (M3 x 0.5p)	D
	Round, as code A, but with Unified thread inserts (4-40 UNC x 0.025)	E
	Rectangular, as code B, but with Unified thread inserts (4-40 UNC x 0.025)	F
AXES	Single axis with analogue track	Y
	Dual axis	XY
TRACKS	Analogue potentiometer, 4k, 0-100%, $\pm 5^\circ$ directional switch	NN
	Analogue potentiometer, 5k, 10-90%, $\pm 5^\circ$ directional switch	RR
	Analogue potentiometer, 8k, 25-75%, $\pm 5^\circ$ directional switch	QQ
DETENTS	Not available with analogue tracks	-/-
LEVER SPRING FORCE	Light duty, 2N breakout, 7.5N full deflection	LA
	Medium duty, 2.5N breakout, 11N full deflection	MA
	Heavy duty, 3N breakout, 12N full deflection	HA
HANDLE STYLES See page 18	Standard handle, no functions	ZC
	Standard handle with momentary push button	ZC1
	Standard handle with momentary switch action	ZCS
	Rotary Z axis handle with analogue track and directional switch	ZA or ZA2
	Rotary Z axis handle with end of travel switches only	ZAS
GATE (lever movement limiter)	Square	S
	Round	R
	Diamond	D
	Cross - only suitable for use with non-switched handles (ZC)	C
SEAT	Aligned with axis	P
	Non-aligned	N

EXAMPLE ORDER CODE

JC400-A-XY-NN-/-MA-ZA-S-P

JC400

MULTI AXIS JOYSTICK DIGITAL OUTPUT

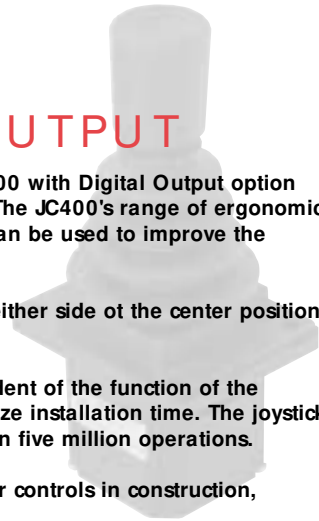

Developed for use in applications where compact size and functionality are important, the JC400 with Digital Output option offers fingertip control in one or two axes, with a choice of handles for a third axis of control. The JC400's range of ergonomic handles feature rotary operated potentiometers, or switches, or 'Person Present' switches that can be used to improve the integrity of your control system.

The Digital track option includes a detent mechanism that provides three sequential positions either side of the center position. The detent positions align with the switch outputs in true X and Y directions only.

Installation flexibility has been provided by using different forms of mounting flanges independent of the function of the joystick, and the digital output joysticks are fitted with standard electronic connectors to minimize installation time. The joystick has been designed for maintenance-free operation throughout an operating life of greater than five million operations.

Typical applications include remote control chest packs, CCTV camera controls and the operator controls in construction, agricultural or material handling equipment.

PERFORMANCE MECHANICAL

Lever operating force breakout	N	3, 4 or 6*
operating	N	12, 13.5 or 18* (full deflection)
maximum allowable	N	250* (full deflection)
Lever mechanical angle	°	± 20 in X and Y directions
Lever action (options)		Self centering, aligned X and Y or non aligned
Lever gate profiles (options)		Single axis, square, round, diamond or cross.
Expected life		> 5 million operations
Weight	g	150 nominal, without handle fitted *50mm above mounting flange face

ENVIRONMENTAL

Operating temperature	°C	-40 to + 70
Storage temperature	°C	-50 to + 85
Environmental protection above flange		IP65 IEC 60529

ELECTRICAL

Number of switch positions		3 either side of center
Number of detents		3 either side of center
Switch/detent angles	°	± 6.6, ± 13.3, ± 20
Supply voltage - maximum	Vdc	30
Load current - maximum	mA	100 resistive @ 25°C

TRUTH TABLE

Truth table for digital switch track output Y and X axis signals are Normally Open (0) at lever center position. Switch sequences close (1) depending on direction of lever movement and detent position.

Detent Position	Switch Output			Right (or Forward)	Left (or Backward)
	1	2	3		
3	1	1	1	1	0
2	1	1	0	1	0
1	1	0	0	1	0
0	0	0	0	0	0
-1	1	0	0	0	1
-2	1	1	0	0	1
-3	1	1	1	0	1

DIMENSIONS

Note: drawings not to scale

INSTALLATION

The joystick is designed to be fitted from below the mounting panel, through a 37mm x 37mm square hole. The effectiveness of the joystick flange sealing is dependent on the panel mounting surface being sufficiently rigid to compress the sealing gaiter. The surface finish of the mounting panel is also critical to achieving an adequate seal and rough surface finishes, paint chips, deep scratches, etc. should be avoided.

Recommended panel thickness

3.5 to 6mm

Recommended screw torque

The JC400 joystick has three options for each mounting flange style, which include through holes and thread inserts in the 4mm diameter holes. To maintain an effective seal between the joystick flange and the mounting panel, the mounting screws should be tightened to a suitable torque to match the selected attachment screw size.

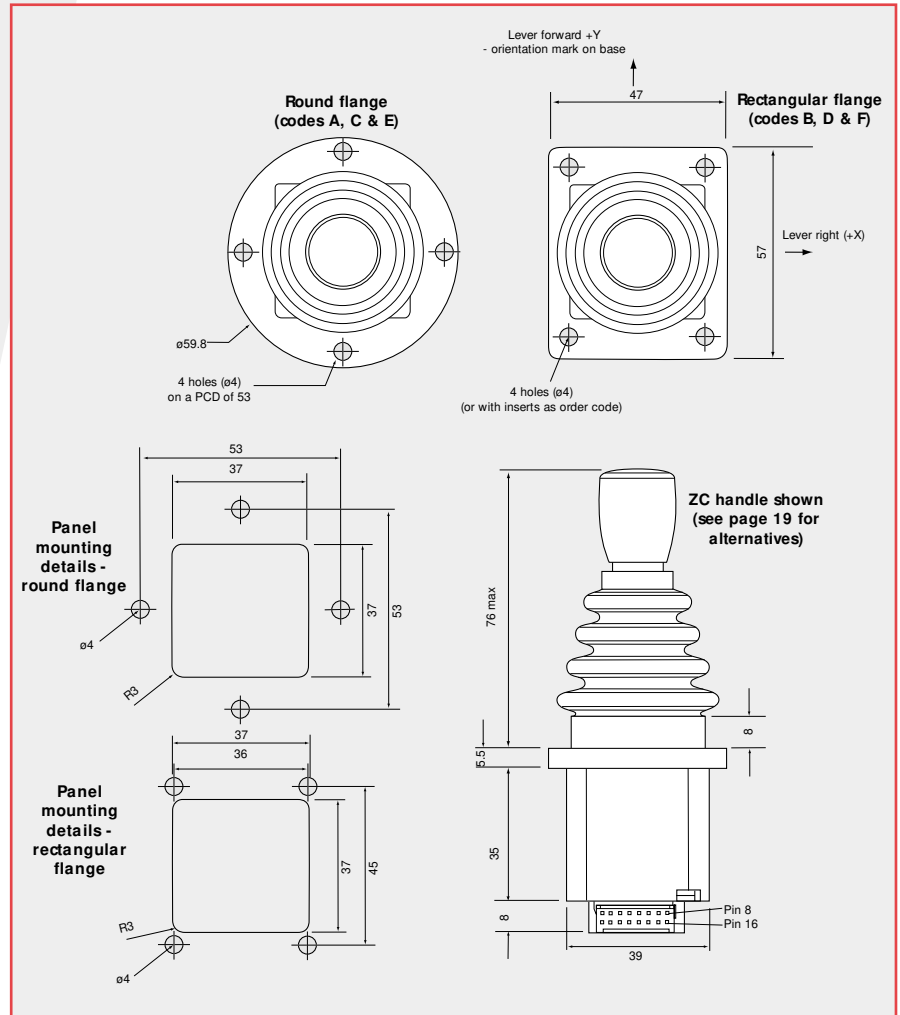

ELECTRICAL CONNECTIONS

Connection

Mating connector and pins kit
(order separately)

FCI DUBOX™ 2 x 8 way male connector (76385-308)

SA47363 (contains DUBOX™ 65239-008, 65239-002 and 65239-003 female connectors and pins 76357-301 suitable for AWG 22-30 wire size)

Requires crimping pliers (FCI No. HT234) to fit pins to wires.

Description	Connector Pin Number
Y axis switch 1	3
Y axis switch 2	14
Y axis switch 3	16
Y axis signal N/O (lever forward + Y)	9
Y axis signal N/O (lever backward -Y)	1
Y axis switch track common	5
X axis switch 1	4
X axis switch 2	7
X axis switch 3	10
X axis signal N/O (lever right + X)	2
X axis signal N/O (lever left -X)	6
X axis switch track common	5

JC400 DIGITAL OUTPUT

HOW TO SPECIFY

PERFORMANCE OPTIONS

MOUNTING FLANGE

AXES

TRACKS

DETENTS

LEVER SPRING FORCE

HANDLE STYLES

See page 18

GATE

(lever movement limiter)

SEAT

FEATURES

Round flange, 59.8mm diameter with 4 x 4mm through holes
 Rectangular flange, 47 x 57mm with 4 x 4mm through holes
 Round, as code A, but with Metric thread inserts (M3 x 0.5p)
 Rectangular, as code B, but with Metric thread inserts (M3 x 0.5p)
 Round, as code A, but with Unified thread inserts (4-40 UNC x 0.025)
 Rectangular, as code B, but with Unified thread inserts (4-40 UNC x 0.025)

Single axis with digital track
 Dual axis

Digital - 3 switches either side of center

Only available with digital tracks

Light duty, 3N breakout, 12N full deflection
 Medium duty, 4N breakout, 13.5N full deflection
 Heavy duty, 6N breakout, 18N full deflection

Standard handle, no functions
 Standard handle with momentary switch action
 Rotary Z axis handle with analogue track and directional switch
 Rotary Z axis handle with end of travel switches only

Square
 Round
 Diamond
 Cross - only suitable for use with non-switched handles (ZC)

Aligned with axis
 Non-aligned

CODE

A
 B
 C
 D
 E
 F

X
 XY

DD

D

LD
 MD
 HD

ZC
 ZCS
 ZA or ZA2
 ZAS

S
 R
 D
 C

P
 N

EXAMPLE ORDER CODE

JC400-B-XY-DD-D-MD-ZC-R-N

JC400 MULTI AXIS JOYSTICK HANDLE OPTIONS



ZA

The ZA and ZAS handles are designed to give an additional axis of proportional or switched control, using fingertip action to rotate the handle. The handles have a self-centering action when released, and rotate about their center, giving either analogue output with switched reference signals (ZA or ZA2) or end of travel switching only (ZAS).

ZC

The convex top profile of the ZC handle allows for simple thumb control of the JC400 range. 'Person present' switch functions can be incorporated by using the ZC1 external button switch or the ZCS internal switch to verify the change in signals from the joystick, which may help to increase the integrity of your control system.



ZA HANDLE OPTION

PERFORMANCE

		ZA, ZA2	ZAS
Max height above flange	mm	80	80
Maximum diameter	mm	39	39
Operating temperature	°C	-25 to + 50	-25 to + 50
Environmental sealing (IEC 60529)		IP65	IP65

Z AXIS MECHANICAL

Handle rotational torque		
breakout	Nm	0.1
operating	Nm	0.15 to 0.25
maximum allowable	Nm	1
Handle mechanical angle	°	± 29 to ± 30
Handle action		Self centering
Expected life		1 million operations

Z AXIS ELECTRICAL

Analogue track (ZA and ZA2 only)

Resolution		Virtually infinite	Center tap angle	°	± 2.5
Track resistance ± 20%	kΩ	3.1 or 5.4 (ZA2)	Supply voltage - maximum	Vdc	30
Track operating angle	°	± 27	Wiper circuit impedance	MΩ	> 0.1**
Output voltage range	%	7-93 or 25-75 (ZA2) of input	Power dissipation @ 20°C	W	0.25(no load)
Center tap voltage (no load)	%	47 - 53 of applied voltage			

** The long life resistive elements require a high impedance load in the wiper circuit to minimise the current flowing through the wiper for optimum conditions

Z AXIS ELECTRICAL

Directional or Centre Switch

		ZA, ZA2	ZAS
Switch operating angle	°	4 either side of center (± 1)	20 either side of center (± 2)
Supply voltage - maximum	Vdc	30	30
Load current - maximum	mA	2 (resistive)	2 (resistive)

DIMENSIONS

Note: drawings not to scale

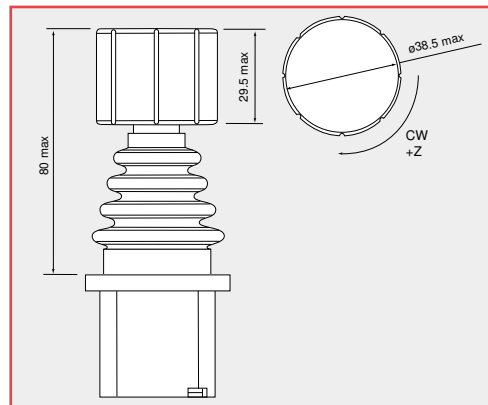

Installation note

The protective rubber cap must be removed before fitting the joystick through the mounting hole. Re-fit the rubber cap after mounting in the panel.

ELECTRICAL CONNECTIONS

Leads exit from the underside of the mounting flange. PVC insulated 7/0.2 (24AWG) flying leads, 240mm long

Description

Flylead colour

	ZA	ZAS
Z axis positive voltage supply	Yellow/Red	-
Z axis center tap	Blue	-
Z axis negative or zero voltage supply	Violet	-
Z axis output voltage signal	Pink	-
Z switch track N/O (handle CW +Z)	Yellow/Black	Yellow/Black
Z switch track N/O (handle CCW -Z)	White/Red	White/Red
Z switch track common	Red/Blue	Red/Blue

ZC HANDLE OPTION

PERFORMANCE

	ZC	ZC1	ZCS
Max height above flange	mm 76	76	76
Maximum diameter	mm 23	23	23
Environmental sealing (IEC 60529)	IP65	IP65	IP65
Number of switches	0	1	1
Action	-	Momentary button	Momentary handle depress
Switch operating force	N -	3	7
Maximum current	mA -	200 @ 50Vdc	100 @ 30Vdc
Expected life (operations)	-	1 million	500,000

DIMENSIONS

Note: drawings not to scale

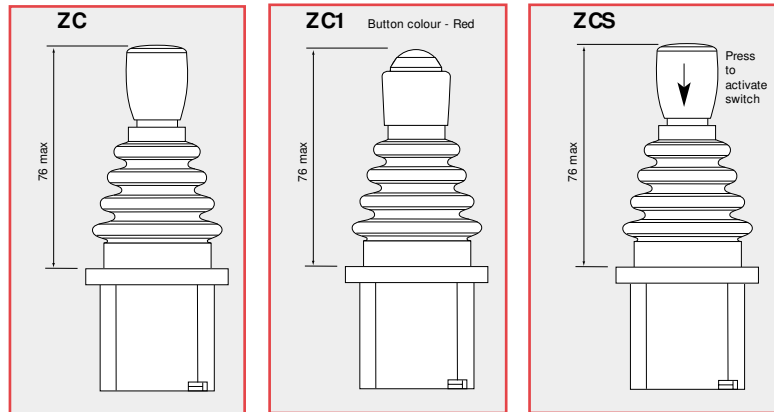

ELECTRICAL CONNECTIONS

Leads exit from the underside of the mounting flange. PVC insulated 7/0.2 (24AWG) flying leads, 240mm long

Description

Common terminal
N/O contact switch 1

ZC1/ZCS Flylead colour

Red/Green
White/Black

SW HANDLE OPTION

OPTION NO-LONGER AVAILABLE

PAGE LEFT INTENTIONALLY BLANK

JC2000

MULTI AXIS CONTACTLESS JOYSTICK

The JC2000 contactless joystick controller is designed for precision fingertip control applications where safety and long trouble-free life are primary requirements. It is available in one, two or three axis configurations and can accommodate a choice of handles, including push-button switch versions. Two mounting flange options allow attachment above or below the panel. The JC2000's compact size, low operational force and high reliability are ideal for applications which include powered wheelchairs, robotics, CMM machines, medical and CCTV equipment, professional camera controls and remote controlled chest-packs.



PERFORMANCE

MECHANICAL

XY axes

Lever operating force

breakout	N	1 or 3*
operating	N	2 or 4.5* (full deflection)
maximum allowable	N	300* (XY version) 195N* (XYZ version)
Lever action (options)		Self centering, aligned X and Y or non aligned
Lever gate profiles (options)		Single axis, round, square, diamond, cross or plus
Lever mechanical angle		
single axis only	°	± 20 in forward/reverse directions
round gate	°	± 20
square and diamond gate	°	± 20 to corners (± 14 to flats)
cross and plus gate	°	± 20 at extent of travel

Expected life

15 million operations (5 million with heavy duty spring)

Weight

g 90 without handle fitted

*Measured 40mm above upper flange face

Z axis (handle style E and HL only)

Handle rotational torque

breakout	Nm	0.04
operating	Nm	0.06
maximum allowable	Nm	1.0

Handle mechanical angle

° ± 20

Handle action

Self centering

Expected life

5 million operations

ENVIRONMENTAL

Operating temperature

°C -25 to +70

Storage temperature

°C -40 to +70

Environmental protection above flange

IP65 IEC 60529

EMC immunity level

60V/m, 25MHz to 1GHz, 1KHz 80% sine wave modulation, EN50082-2 (Sept 1995)

EMC emissions level

Complies with EN50081-1 (1992), 30MHz to 1GHz

ESD immunity level

EN50082-2 (1995) ± 8kV contact discharge; ± 15kV air discharge (10 discharges)

ELECTRICAL

Sensor type

Hall effect

Resolution

Infinite

Supply voltage range Vs

Vdc 5 ± 0.5 regulated transient free

Over voltage (maximum)

Vdc 15 continuous

Reverse polarity (maximum)

Vdc 14.5

Output voltage span (options)

	Gate option	Minimum	Nominal	Maximum
X, XY and XYZ** Code 25	Vdc 1, R, D, C, P	1.25 to 3.75	1.10 to 3.90	0.97 to 4.03
	Vdc S**	1.67 to 3.32	1.55 to 3.45	1.43 to 3.57
Code 30	Vdc 1, R, S, D, C, P	1.15 to 3.85	1.00 to 4.00	0.85 to 4.15
Code 40	Vdc 1, R, D, C, P	0.65 to 4.35	0.50 to 4.50	0.35 to 4.65
	Vdc S	1.10 to 3.90	0.80 to 4.20	0.50 to 4.50

** consult sales team for available options

Output impedance	Ω	100 each axis
Center reference output (no load)	%	49 - 51 of supply voltage V_s
Center reference impedance	$k\Omega$	1.1
Current consumption - max	mA	24
Return to center voltage-no load	mV	X and Y axis Within ± 60 of $V_s/2$ @ 20°C (± 73 over full temperature range)
		XY with gate S Within ± 113 of $V_s/2$ @ 20°C (± 126 over full temperature range)
		Z axis Within ± 100 of $V_s/2$ @ 20°C (± 113 over full temperature range)
Output ramp		XY axes The dual outputs of the XY axes can be independently selected to be rising together in the same direction (PP) or opposed (PN). See order code
		XYZ The three axis version can only provide a single output per axis

DIMENSIONS

Top flange option

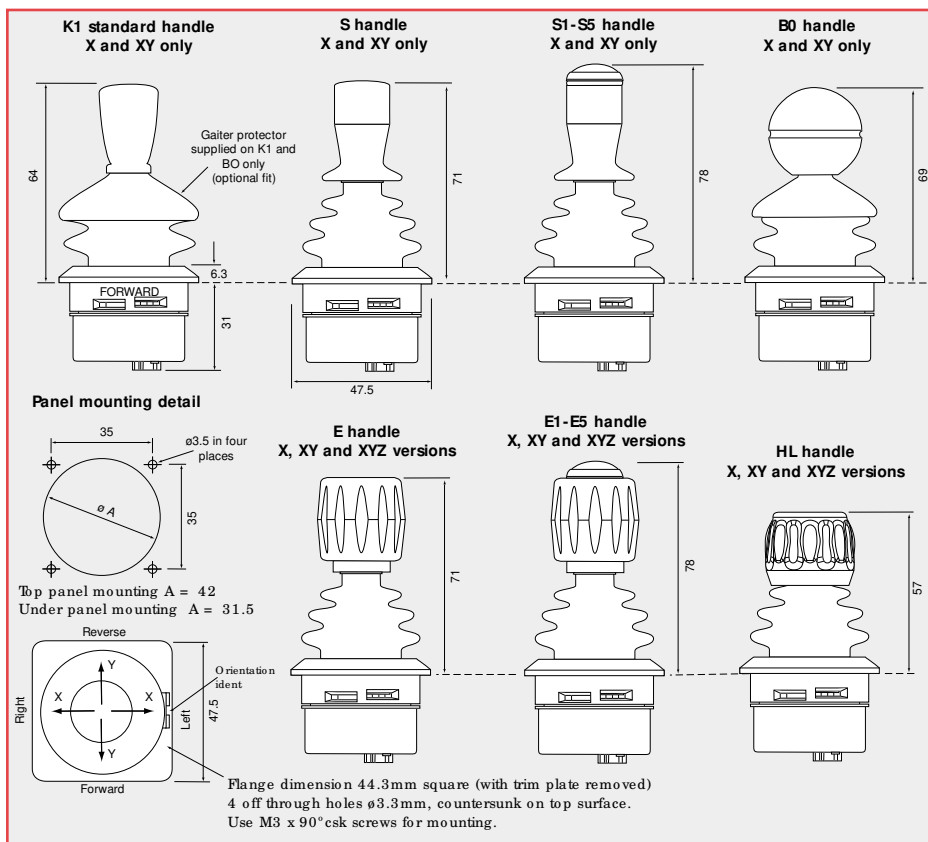

DIMENSIONS

Mid flange option
 X and XY axes only

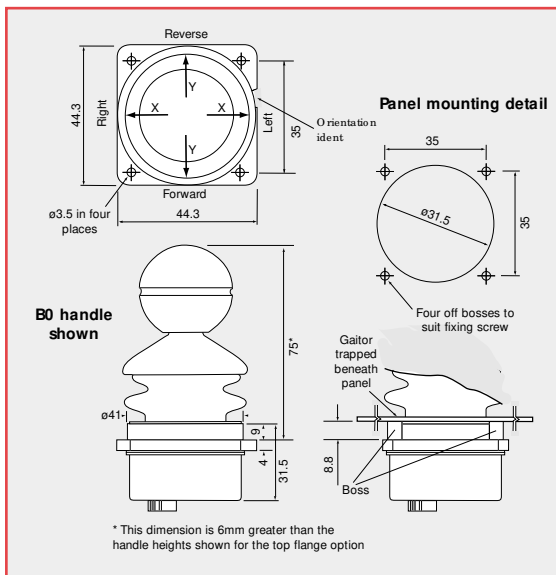

OUTPUT TRACKING

Output shown for same direction - PP or NN

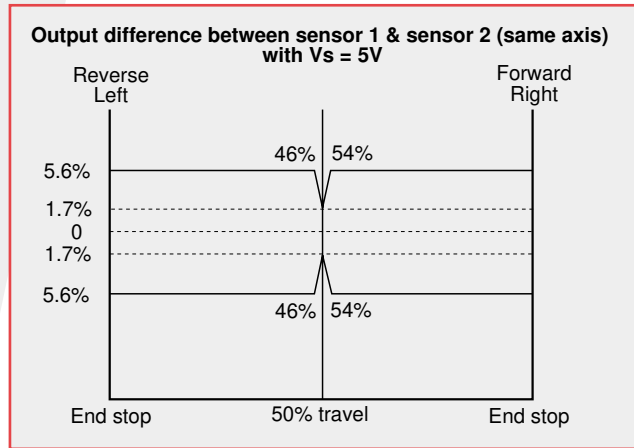

ELECTRICAL CONNECTIONS

Mating Connector

8 Pin FCI Minitex™ 89361-708 IDC Connector (order separately as P302137) or supplied with 0.5m ribbon cable fitted (order as P302138)

	Pin Number	Description
	1	Positive voltage supply
	2	Left/Right output 1
	3	Zero voltage supply
	4	Forward/Reverse output 1
	5	Forward/Reverse output 2
	6	Center tap
	7	Left/Right output 2
	8	Switch output (NC if no switch)
		Switch is connected between pin 1 and 8

JC2000 MULTI AXIS CONTACTLESS JOYSTICK HOW TO SPECIFY

PERFORMANCE OPTIONS	FEATURE	CODE	FEATURE AVAILABILITY		
			X	XY	XYZ
MOUNTING FLANGE	Top flange	JC2000-T	✓	✓	✓
	Mid flange (not available with XYZ)	JC2000-M	✓	✓	
AXES	Single axis	X	✓		
	Dual axis	XY		✓	
	Three axis (only available with top flange)	XYZ			✓
OUTPUT RAMP	dual output - same ramp	PPOOO	✓		
	dual output - opposite ramp	PNOOO	✓		
	dual output - same ramp each axis	PPPPPO		✓	
	dual output - same ramp X, opposite ramp Y	PPNNO		✓	
	dual output - opposite ramp each axis	PNPNO		✓	
	single output - same ramp each axis	POPOP			✓
	single output - same ramp X and Z, opposite ramp Y	PONOP			✓
	single output - same ramp Y and Z, opposite ramp X	PONON			✓
	single output - opposite ramp each axis	NONON			✓
OUTPUT SPAN	1.1 to 3.9 Vdc nominal	25	✓	✓	✓
	1.0 to 4.0 Vdc nominal	30	✓	✓	✓*
	0.5 to 4.5 Vdc nominal	40	✓	✓	✓*
HANDLE STYLES See page 23	Standard tapered handle	K1	✓	✓	
	Ball handle	B0	✓	✓	
	Short ergonomic handle	HL	✓	✓	✓
	Ergonomic handle	E	✓	✓	✓
	Ergonomic with Black push button	E1	✓	✓	✓
	Ergonomic with Red push button	E2	✓	✓	✓
	Ergonomic with Green push button	E3	✓	✓	✓
	Ergonomic with Yellow push button	E4	✓	✓	✓
	Ergonomic with Blue push button	E5	✓	✓	✓
	Straight handle	S	✓	✓	
	Straight with Black push button	S1	✓	✓	
	Straight with Red push button	S2	✓	✓	
	Straight with Green push button	S3	✓	✓	
	Straight with Yellow push button	S4	✓	✓	
	Straight with Blue push button	S5	✓	✓	
GATE (lever movement limiter)	Single axis	1	✓		
	Round	R		✓	✓
	Square*	S		✓	✓
	Diamond	D		✓	✓
	Cross X	C		✓	✓
	Plus +	P		✓	✓
SEAT	Aligned with axis	P		✓	✓
	Non-aligned	N	✓	✓	✓
LEVER SPRING FORCE	Standard duty, 1N breakout, 2N full deflection	S	✓	✓	✓
	Heavy duty, 3N breakout, 4.5N full deflection	H	✓	✓	✓

EXAMPLE ORDER CODE JC2000-T-XY-PPPPPO-40-E5-R-P-H

Two axis version with all outputs same sense, 40% output span, ergonomic handle style with Blue push button switch, round gate and aligned seat, with heavy spring.

*Consult the sales team for available output span options, when selecting XYZ with S gate option.

GENERAL NOTES ON FINGER OPERATED JOYSTICKS

MECHANICAL LOADS

Penny+ Giles joystick controllers are robust and designed to suit typical applications. System designers should ensure that the joystick is not positioned where it could be subjected to excessive loads greater than the maximum allowable load stated in the product specification.

MODIFICATION AND USAGE

Any modification of a joystick by the user is strongly discouraged and will invalidate the warranty and Penny+ Giles liability. The handles supplied with the finger operated controllers are intended for fingertip and not full hand operation. Handles **must not** be replaced with a taller handle otherwise the increased load applied to the joystick may result in permanent damage.

USER MAINTENANCE/ ADJUSTMENT

All joysticks are supplied by Penny+ Giles fully adjusted and ready for installation. There are no user adjustable or maintainable parts within the joysticks. Any attempt to dismantle the joystick will invalidate the warranty and may leave the system into which the joystick is installed in a dangerous condition.

SAFETY

For a system to operate safely it must be able to differentiate between commanded and uncommanded inputs. System designers should take steps to detect and manage joystick and system failures that may give rise to an erroneous output. For safety critical functions we recommend that an independent momentary action 'system enable' switch is used. This switch can be incorporated into the joystick as a 'Person Present' switch or can be a separate foot or hand operated momentary switch. All functions controlled by the joystick should be disabled when this switch is released. The control system should look for the appropriate 'system enable' switch output before the joystick is displaced from the neutral position. Functions controlled by the joystick should not be enabled until this is the case.

JOYSTICK INTEGRITY CHECK ON POWER UP

On system power-up, the system should check that all joystick outputs are in neutral and safety critical functions controlled by the joystick should not be enabled until this is the case.

LIFE

Penny+ Giles joysticks are designed and tested to provide a working life that is acceptable for the majority of applications. System designers should be satisfied that the life stated in the joystick specification is sufficient for the intended application.

JC2000 INSTALLATION AND APPLICATION NOTES

SEALING THE JOYSTICK TO THE PANEL

See panel mounting detail on page 23 for recommended machining detail to accept the JC2000. Prior to installation check that the gate (lever movement limiter) positioned under the gaiter at the top of the joystick is correctly located and orientated.

The joystick is sealed above the mounting surface to prevent dust and water ingress to IP65 and is supplied with mounting hardware (sealing gasket and trim plate) suitable for mounting from above the panel face. The effectiveness of the seal is dependent on the mounting surface being sufficiently rigid to compress the sealing gasket. The finish of the mounting surface is critical to achieving an adequate seal and rough surface finishes, paint chips, deep scratches etc. should be avoided. The joystick should not be used if the flexible rubber gaiter becomes perforated.

Below the mounting surface the joystick should be allowed to breathe freely but be protected from excessive dust and direct water spray. Where the joystick is mounted in a control box, the box should be allowed to breathe at its lowest point. If the box is subjected to water spray it may be necessary to provide a waterproof breather at the lowest point.

It is possible to mount the JC2000 from under the panel surface by discarding the trim plate and sealing gasket and compressing the base of the flexible gaiter against the panel and mounting flange. This reduces the lever height above the panel, but increases the space required to accommodate the joystick body below the panel. See panel mounting detail on page 23 for dimensions.

DUAL OUTPUTS - X AND XY VERSIONS ONLY

Each JC2000 joystick axis is equipped with two outputs and it is recommended that both outputs are continuously compared to ensure that the difference does not exceed the maximum specified difference plus a suitable 'safety margin'. In addition, machine movement should not be enabled until both outputs from any one axis exceed the centre threshold voltage plus a suitable 'safety margin'. (e.g. 2 x joystick centre tolerance)

The outputs in normal use are within the maximum span limits shown on page 22. Any output significantly outside of this range must be regarded as erroneous and appropriate safe action taken. A high value pull-up or pull-down resistance should be added to the X and Y outputs such that in the unlikely event of a wire or connector failure the output will be pulled out of range.

DUAL OUTPUT SENSE (DIRECTION)

Dual outputs from any JC2000 joystick axis can be configured during manufacture in one of two possible ways. These are designated within the joystick specification as same-ramp (P) or opposite-ramp (N). The diagrams, below, show dual outputs; for single output or a Z axis either output 1 or 2 can be chosen.

The ramps at their lower end start at 25%, 20% or 10% of supply voltage and at their upper end finish at 75%, 80% or 90% of supply voltage, depending on output option.

In the same-ramp configuration the outputs of an axis can be directly compared to determine the serviceability of the joystick.

In the opposite-ramp configuration the sum of the outputs from any axis should within limits, equal the applied voltage.

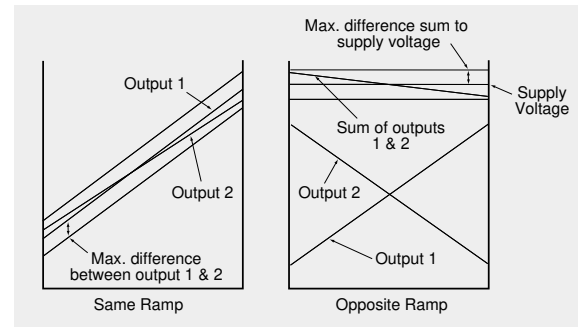

CENTER TAP

A center tapping is provided as a means of verifying the integrity of the supply voltage at the joystick. Clearly a high resistance or open circuit in either the +ve supply or 0V connections will affect the joystick outputs. The normal output at the center tap connection is 49% to 51% of the supply voltage. A center tap output outside this range indicates a fault in the supply to the joystick.

SINGLE OUTPUTS - XYZ ONLY

Where a JC2000 joystick incorporating only a single sensor per axis is used to control safety critical functions an independent momentary action system enable switch must be provided.

OUTPUT IMPEDANCE

The outputs at the center position and the end of travel are specified with an infinite load impedance or zero current. The effect of adding a finite load impedance will be to source or sink current through the joystick output impedance. The voltage dropped through the joystick output impedance must be taken into account when the system threshold voltages are being defined. The impedance of the JC2000 outputs are specified on page 23.

OUTPUT NOISE

The JC2000 incorporates Hall effect sensors to detect the position of each of the joystick axes. A side effect of the use of these sensors is electrical noise superimposed on the output, typically of the order of 20mV peak to peak. This noise can be simply filtered out by the user.

MAGNETIC IMMUNITY

Magnetic screening minimises the sensitivity to external magnetic fields. However the use of the joystick in close proximity to sources of high magnetic fields is not recommended.

APPLIED VOLTAGES

The JC2000 is designed to operate from a regulated 5Vdc \pm 0.5V supply, free from voltage transients. Under no circumstances should voltages above 5.5V be applied to the joystick. The outputs from the JC2000 are ratiometric and are dependent on the input voltage.

CURTISS - WRIGHT

www.cw-industrialgroup.com

Penny & Giles
Position sensors, joysticks and
solenoids for commercial and
industrial applications.

36 Nine Mile Point Industrial Estate
Cwmfelinfach
Gwent NP11 7HZ
United Kingdom
+44.1495.202000
cwig.uk@curtisswright.com

10 Airspeed Road
Christchurch
Dorset BH23 4HD
United Kingdom
+44.1425.271444
cwig.uk@curtisswright.com

210 Ranger Street
Brea, CA 92821
USA
+1.714.982.1862
cwig.us@curtisswright.com

Schleissheimer Str. 91A
85748 Garching
Germany
+49.89.5404.100.0
cwig.de@curtisswright.com

Rm 1007, No.8 Dong An Rd
No.8 Dong An Rd
Shanghai, 200032
People's Republic of China
+86.21.3331.0670
cwig.cn@curtisswright.com

The information contained in this brochure on product applications should be used by customers for guidance only. Penny & Giles Controls Ltd makes no warranty or representation in respect of product fitness or suitability for any particular design application, environment, or otherwise, except as may subsequently be agreed in a contract for the sale and purchase of products. Customer's should therefore satisfy themselves of the actual performance requirements and subsequently the products suitability for any particular design application and the environment in which the product is to be used.

Continual research and development may require change to products and specification without prior notification. All trademarks acknowledged.

© Penny & Giles Controls Ltd 2007

Innovation In Motion