

Operating and installation instructions

R-IMC-BUS / Profibus
Filter control system

RM-350 C

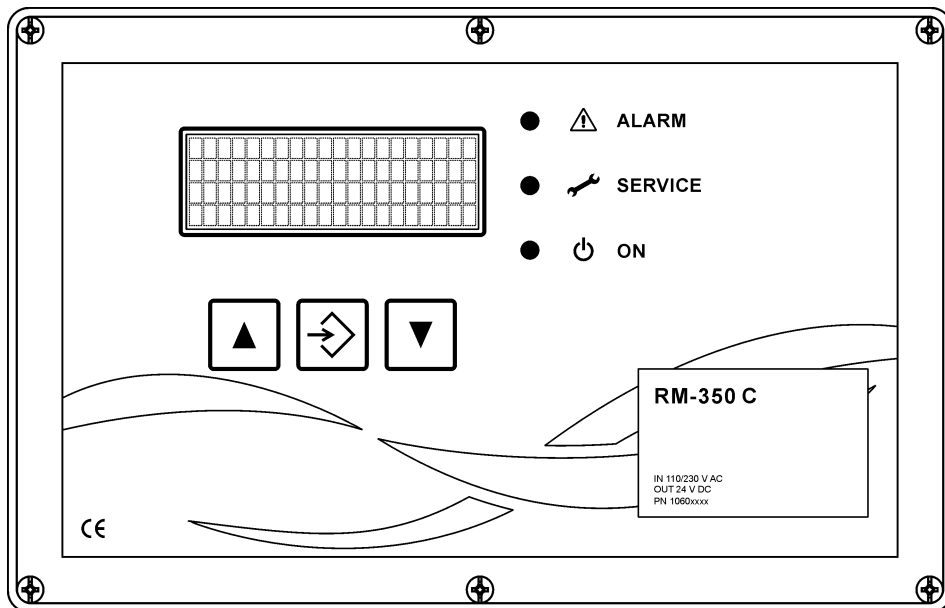

Contents

1	Safety instructions	3
2	Device description	3
3	Installation	4
4	Step-by-step installation	4
5	Step-by-step setting procedure	9
5.1	Function in "as delivered" condition.....	9
5.2	Operating and display elements	9
5.3	Parameter selection level	10
	Parameter blocks	10
	Activated and deactivated parameters / faded in and faded out parameters	10
	Parameter display examples.....	10
5.4	Parameter setting level	12
5.5	Code input to clear locked parameters.....	12
5.6	Return to the operating level	12
5.7	Short guide for parameter setting	13
5.8	Overview of menu navigation	14
5.9	Parameter list.....	19
5.10	Parameter description and explanation of function	21
6	Operating modes	28
6.1	Time-controlled cleaning (parameter E1, E5, D1).....	28
6.2	Forced cleaning (parameter E8).....	28
6.3	Differential pressure-controlled cleaning (parameter D5, D6, D1)	28
6.4	Downtime (parameter E9)	28
6.5	Cleaning skip range (parameter EC).....	28
6.6	Individual cleaning diagram (parameter ED).....	28
6.7	Optional Profibus operation (parameter N0)	28
6.8	Valve test mode	29
7	Troubleshooting.....	30
8	Text messages on the display.....	32
8.1	Program start	32
8.2	Operating message 1	32
8.3	Operating messages 2 to 4	34
8.4	Operating message 5 – only with active service operating hours counter.....	34
8.5	Operating message 6 – with activated humidity measurement only	35
8.6	Service and alarm messages	35
9	Glossary	37
10	Technical specifications	39

Regulations

2014/30/EU

2014/35/EU

Symbol explanation



Important note



Important warning

1 Safety instructions



The RM-350 C filter control carries hazardous electrical voltage when connected to the mains. Improper installation of the connected electrical equipment may cause device failure, serious or even fatal injuries. In addition to general safety rules for equipment in industrial electrical installations, pay particular attention to the following points:

- The equipment must only be installed by qualified persons according to the provisions of the standards IEC 364 and DIN VDE 0105 for electrical equipment.
- All applicable laws, conditions, rules and regulations governing the installation of electrical equipment must be observed.
- Equipment with protection rating IP00 without covers must only be configured by authorised expert staff when disconnected and whilst observing the local safety and accident prevention rules.
- The RM-350 C filter control must only be operated within the permitted application range.
- Switch off the supply voltage before replacing the filter controller or components connected to it. Failure to do so may cause equipment damage.

2 Device description

The RM-350 C controller is the master control of the modular filter control system for filtering separators with compressed air pulse cleaning. The visualisation and control unit RM-VISIO 80 serves to display operating and alarm messages and to parameterise the controller. The intelligent I/O modules handle decentral measuring and control tasks.

The R-IMC-Bus (RECO – Inter Module Communication) employed for data transfer between the individual control components was developed specifically for use in industrial environments. The data exchange with the external components takes place via the Profibus.

Once the supply voltage and the intelligent I/O modules have been connected the RM-350 C filter control works fully automated without further handling.

3 Installation

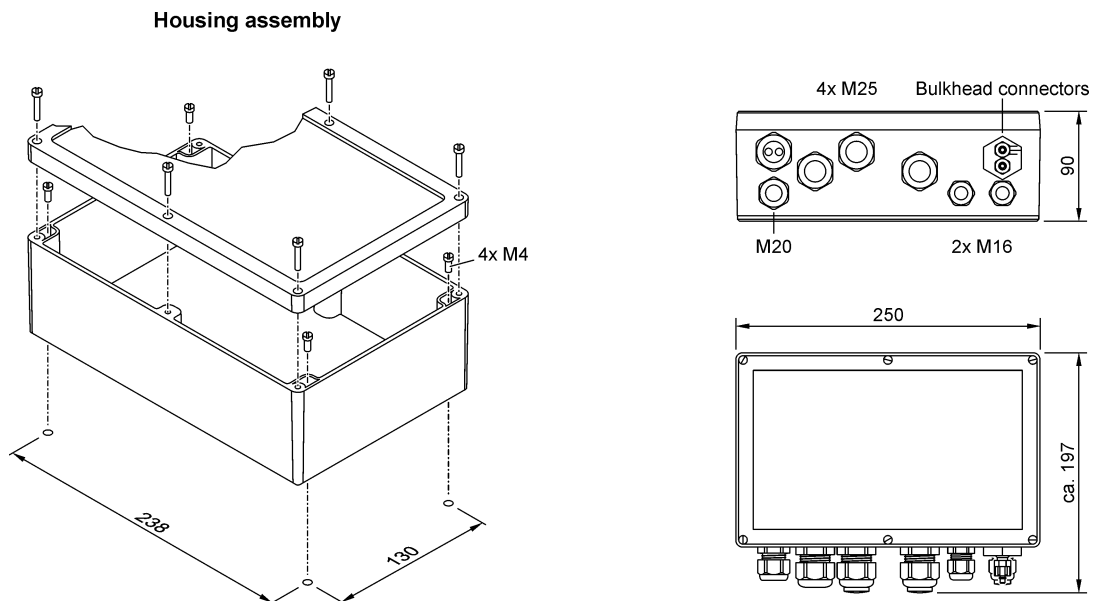

4 Step-by-step installation

1 Power supply connection



Two different device versions are available:

- The version for a supply voltage of 110 V AC and 230 V AC
- The version for a supply voltage of 24 V DC.

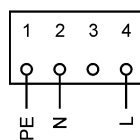

230 V AC

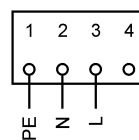

110 V AC

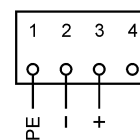

24 V DC

2

R-IMC-Bus connection

I/O modules RM-V8 / RM-V16

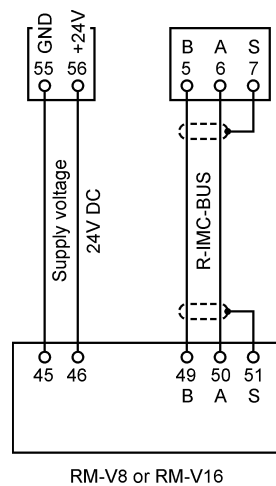

3

Digital input connection E1 ... E8, 24 V DC

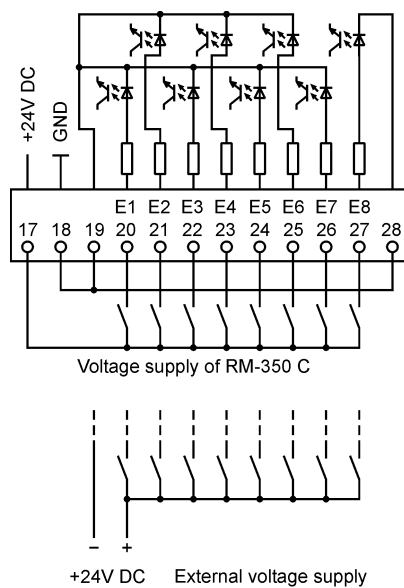

Input	Factory-set function
I1	Release of the control when no signal is present
I2	Continuous cleaning with Interval 1
I3	Cleaning off (priority over Cleaning on)
I4	Acknowledge alarm
I5	Cleaning pressure 100% (The 2/2-way valve of the cleaning pressure controller is always active.) Reset of the cleaning pressure set-point to the "P-Start" value.
I6	No function
I7	No function
I8	No function

i

The function of the inputs can be individually set via parameter group F0-F8. See appendix 7 "Input and output signal parametrisation, special parameter".

4 Connection analogue inputs I1 ... I3

Input	Factory-set function
I1	Δp signal of the filter, external transmitter 4-20 mA 0-5000 Pa
I2	p signal of the cleaning pressure, transmitter 4-20 mA $\hat{=}$ 0-10 bar
I3	Signal from the dust monitoring sensor (if present) or signal from the humidity sensor (if present)*
GND	Ground potential with 4-wire connection
+24V DC	output +24 V DC with 2-wire connection

* If the input I3 is already assigned, the analog input of an I/O module RM-V8 / RM-V16 can be used for the signal from the humidity sensor. In this case, the parameter P1 "Measuring point" has to be set accordingly.

2-wire connection

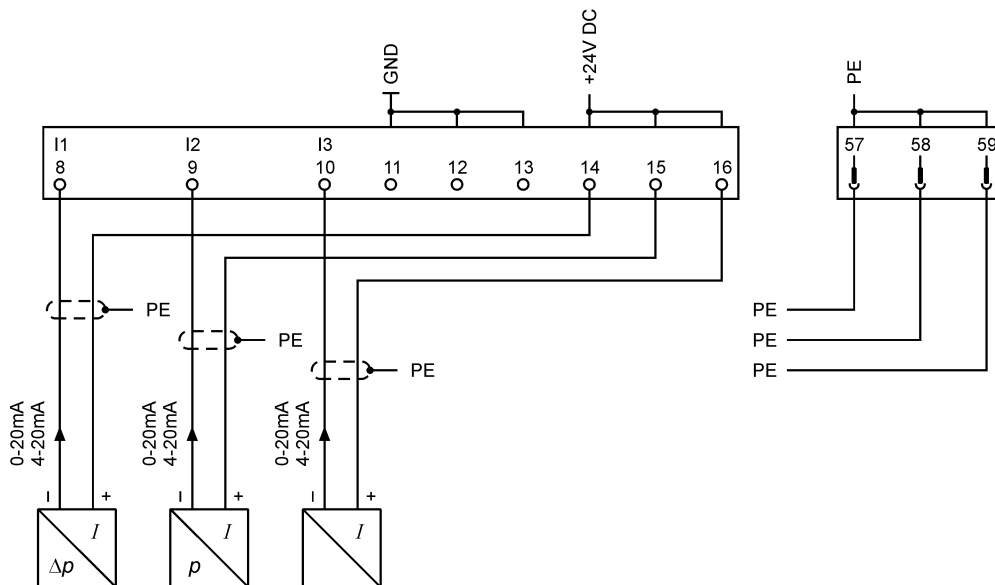

4-wire connection

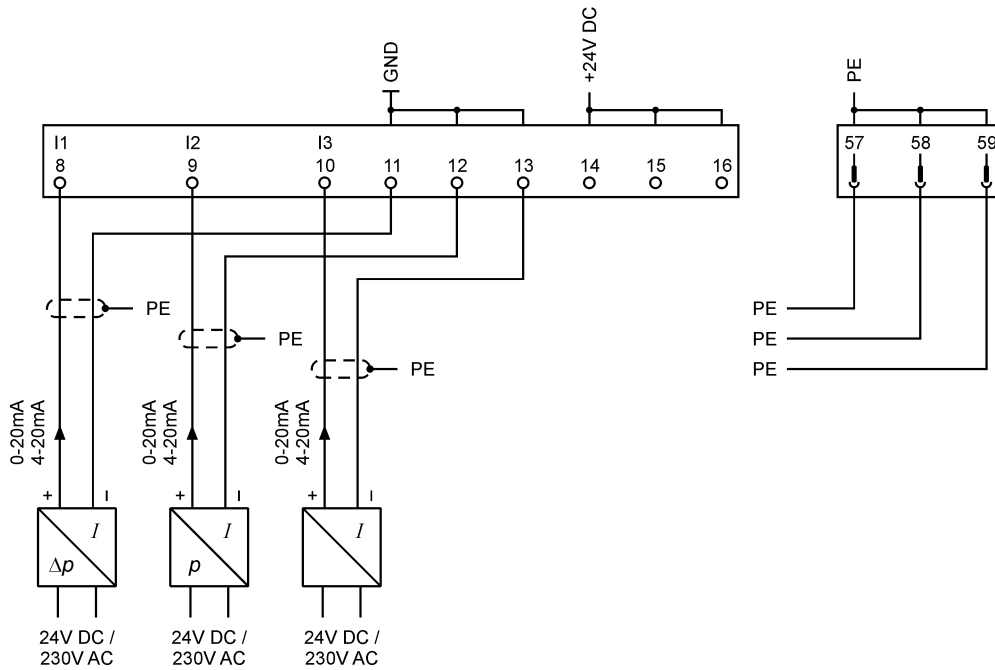

5 Relay outputs A1 ... A4 connection, potential-free

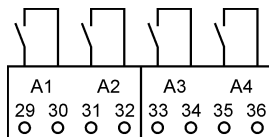

Output	Factory-set function
A1	The relay contact closes as soon as the supply voltage is applied to RM-350 C. It opens any time an alarm is present (Group Alarm).
A2	Contact closes at control release and at downtime
A3	Contact closes at Δp -Alarm
A4	2/2-way valve cleaning pressure controller

i The function of the outputs can be individually set via parameter group G0-G8. See appendix 7 "Input and output signal parametrisation, special parameter".

6 Profibus connection

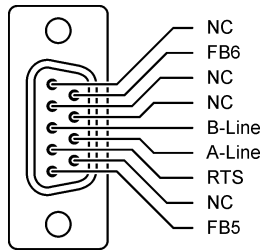

i

- Shielded cables must be used for all bus and analogue signal lines! The shielding is to be applied one-sided and as short as possible.
- Signal cables are not allowed to be installed parallel to power cables.
- All cable glands must be firmly tightened to make sure the cables are solidly enclosed and no water can enter.
- Unused cable glands must be closed and replaced with blind plugs.

5 Step-by-step setting procedure

5.1 Function in "as delivered" condition

The following parameters must be set before operating the RM-350 C:

- E0 Cleaning control functions
- EA Number of valves
- EB Number of I/O modules

The RM-350 C operates automatically once the cleaning control functions, number of valves and number of I/O modules have been set.

Cleaning starts when the filter's differential pressure Δp has reached the "DP-Start" value (factory setting: 1200 Pa). The solenoid valves are controlled sequentially. By cleaning the differential pressure drops after a certain period of time. Once the differential pressure has reached the value "DP-Start" minus "DP-Hyster." (factory setting: 300 Pa), i.e. the differential pressure is 1200 Pa - 300 Pa = 900 Pa, cleaning stops.

If a different function is desired or additional functions shall be activated, the parameter setting of the RM-350 C must be changed. See sections 5.3 "Parameter selection level" to 5.9 "Parameter list" on this.

5.2 Operating and display elements

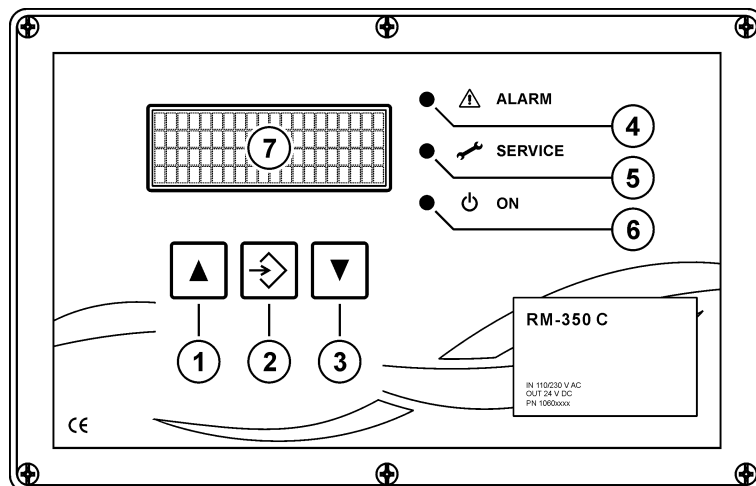

- ① ▲ - key
 - In parameterisation mode* to select parameters or values (in up-arrow direction)
 - In operating mode to call text messages not shown (in up-arrow direction)
- ② ENTER key
 - In parameterisation mode* to confirm parameters
 - If a service or alarm message is present, to acknowledge the message
- ③ ▼ - key
 - In parameterisation mode* to select parameters and values (in down-arrow direction)
 - In operating mode to call text messages not shown (in down-arrow direction)

* the RM-350 C is on the parameter selection or parameter setting level.

- ④ "ALARM" LED Lights when an alarm is present
- ⑤ "SERVICE" LED Lights when the filter requires maintenance.
- ⑥ "ON" LED
Lights when the device is in operation
Does not light when the device is on the parameter selection level
Flashes when the device is on the parameter selection level
- ⑦ Display To display text messages (4 x 20 characters)

5.3 Parameter selection level

To view the parameters and their values the user must switch from the operating level to the parameter selection level. The \triangle and ∇ keys must be pressed simultaneously until the green "ON" LED goes off (approx. 3 seconds).

All parameters with their set values can now be viewed in sequence by repeatedly pressing the \triangle or ∇ key. Inactive or hidden parameters are automatically skipped (see section "Activated and deactivated parameters / faded in and faded out parameters" on this).

Parameter blocks

To ensure an uncluttered view of the device's parametrisation parameters referring to the same function are grouped into blocks (C0, D0, E0, etc.). For example, the block D0 " Δp -controls" includes all parameters (D1, D2, D3, etc.) referring to the differential pressure-dependent cleaning control (short: Δp -controls).

Activated and deactivated parameters / faded in and faded out parameters

Two different types of parameter blocks are available: those that can be activated and deactivated and those that can be faded in and faded out. A deactivated block is inactive. All parameters assigned to it are without function and are not shown. With faded out parameter blocks the associated parameters are active, that is, functioning. They are just not shown.

i To activate a disabled parameter group or to fade in a faded out parameter group switching to the parameter setting level is required (see section 5.4 "Parameter setting level" on page 12 on this).

Parameter display examples

Parameter block C0, deactivated

Display	Meaning
<pre>C0 Ser.ope.hours 0 inactive Parameter code 5</pre>	<p>Parameter block C0 "Service operating hours"</p> <p>The block is inactive (deactivated)</p> <p>The block is protected by Code 5</p>

Parameter block C0, activated

Display	Meaning
<pre>C0 Ser.ope.hours 1 act.w/o mess. Parameter code 5</pre>	<p>Parameter block C0 "Service operating hours"</p> <p>The group is active (activated without message)</p> <p>The block is protected by Code 5</p>

Parameter C1 of parameter block C0

<pre>C0 Ser.ope.hours C1 Counter mode 3 DP / Clean on</pre>	<p>Parameter block C0 "Service operating hours"</p> <p>Parameter C1 "Counter mode"</p> <p>Set value of the parameter C1</p>
---	---

Parameter block D0, faded out

<pre>D0 DP-controls 0 faded out Parameter code 3</pre>	<p>Parameter group D0 "Δp-control"</p> <p>The block is faded out (parameter not visible)</p> <p>The block is protected by Code 3</p>
---	---

Parameter block D0, faded in

<pre>D0 DP-control 1 faded in Parameter code 3</pre>	<p>Parameter group D0 "Δp-control"</p> <p>The block is faded in (parameters are visible)</p> <p>The block is protected by Code 3</p>
---	---

Parameter D1 of parameter block D0

<pre>D0 DP-controls D1 Cleaning mode 1 DP cont.clean. Parameter code 3</pre>	<p>Parameter block D0 "Δp-controls"</p> <p>Parameter D1 "Δp Cleaning mode"</p> <p>Set value of the parameter D1</p> <p>Parameter D1 is protected by Code 3</p>
---	--

Parameter block B0

<pre>B0 Disp.language 0 D - Deutsch</pre>	<p>Parameter block B0 "Display language"</p> <p>The block consists only of parameter B0</p> <p>Set value of the parameter B0</p> <p>The block is not protected by a code</p>
---	--

5.4 Parameter setting level

To change the value of a selected parameter or to activate and deactivate or fade in or fade out a parameter block the user must switch from the parameter selection level to the parameter setting level. To do so, the ENTER key must be pressed until the text display switches over (for parameters locked by a code) or the green LED "ON" begins to flash (with unblocked or previously unblocked parameters).

i For parameters blocked by a code, the entry of a 4-digit code is required to release the parameter (refer to section 5.5 "Code input to clear locked parameters" on this).

Subsequently, the parameter value can be changed or the parameter block activated or deactivated or faded in and faded out by pressing the \triangle or ∇ key.

To save the set value or the status of the parameter block (activated / deactivated or faded in / faded out) and return to the parameter selection level the ENTER key must be pressed until the green LED "ON" goes out (approx. 1 second).

5.5 Code input to clear locked parameters

There are 3 different codes that are used to allow access to certain parameters to authorised persons only. In the parameter selection mode, the row 4 of the display shows what code has to be entered to release the displayed parameter (parameter code 3, 4 or 5). If nothing is displayed in the row 4, the relevant parameter can be accessed without code. The required codes can be found in section 5.9 "Parameter list" on page 18.

The 4-digit code must be entered as follows:

1. The code digit is selected by briefly pressing the ENTER key.
2. The digit value is set by briefly pressing the ∇ or \triangle key.
3. The set code is confirmed by prolonged pressing of the ENTER key.

If the code entered is wrong the message "Invalid input!" appears for 2 seconds. The code input must be repeated.

If the code entered is correct the message "!!!! OK !!!!!" appears for 2 seconds.

All parameters that were blocked by the same code are now released for setting. The parameters are blocked again if no key of the device is pressed for 20 minutes.

5.6 Return to the operating level

To get to the operating level the ∇ and \triangle keys must be pressed simultaneously until the green LED lights (approx. 3 seconds).

5.7 Short guide for parameter setting

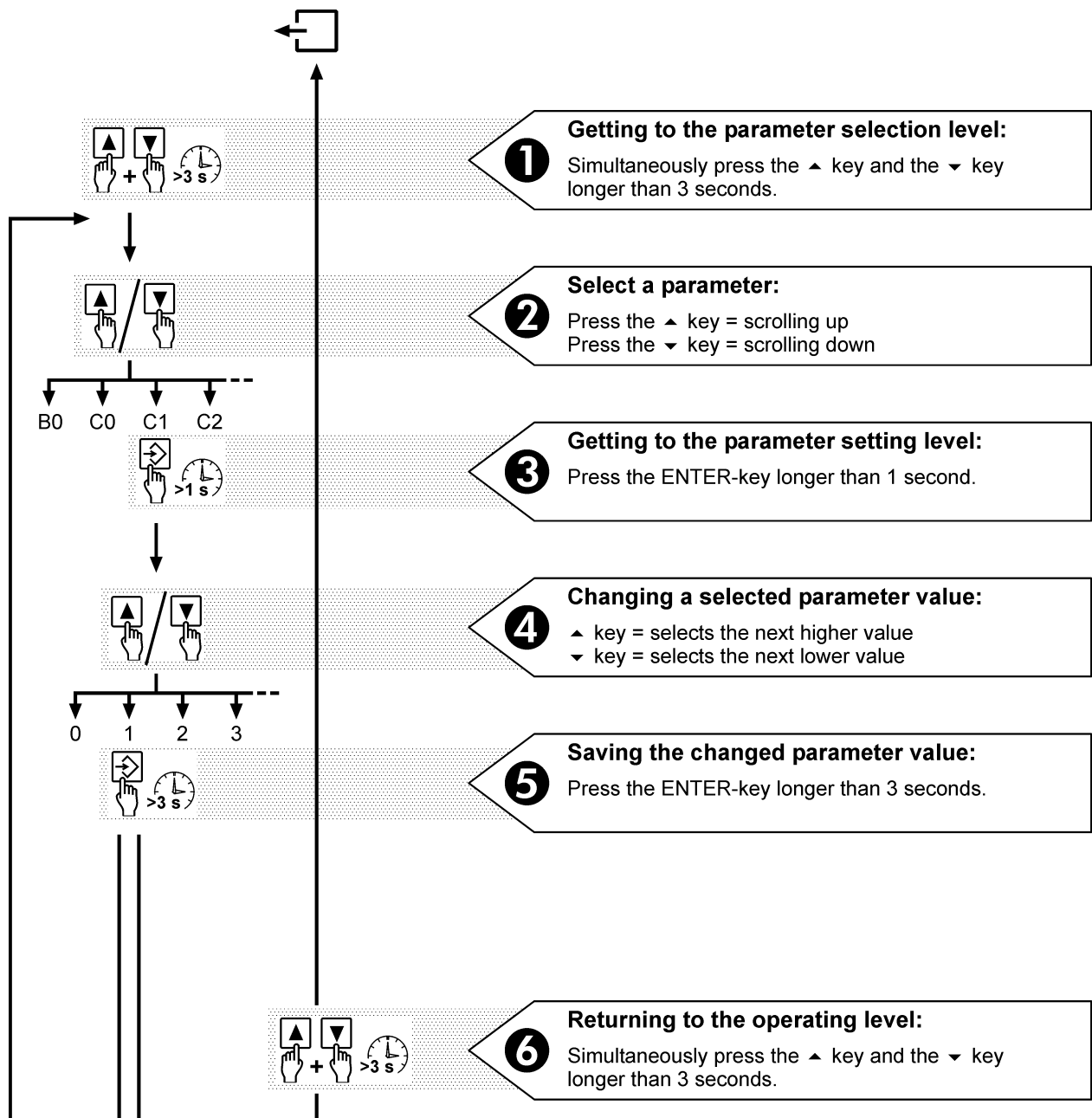

i The ON LED indicates the current level of the device.

LED lights	Operating level
LED off	Parameter selection level
LED flashing	Parameter setting level

If no key has been pressed for 3 minutes the RM-350 C automatically returns from the parameter selection or the parameter setting level with the last values stored to the operating level.

5.8 Overview of menu navigation

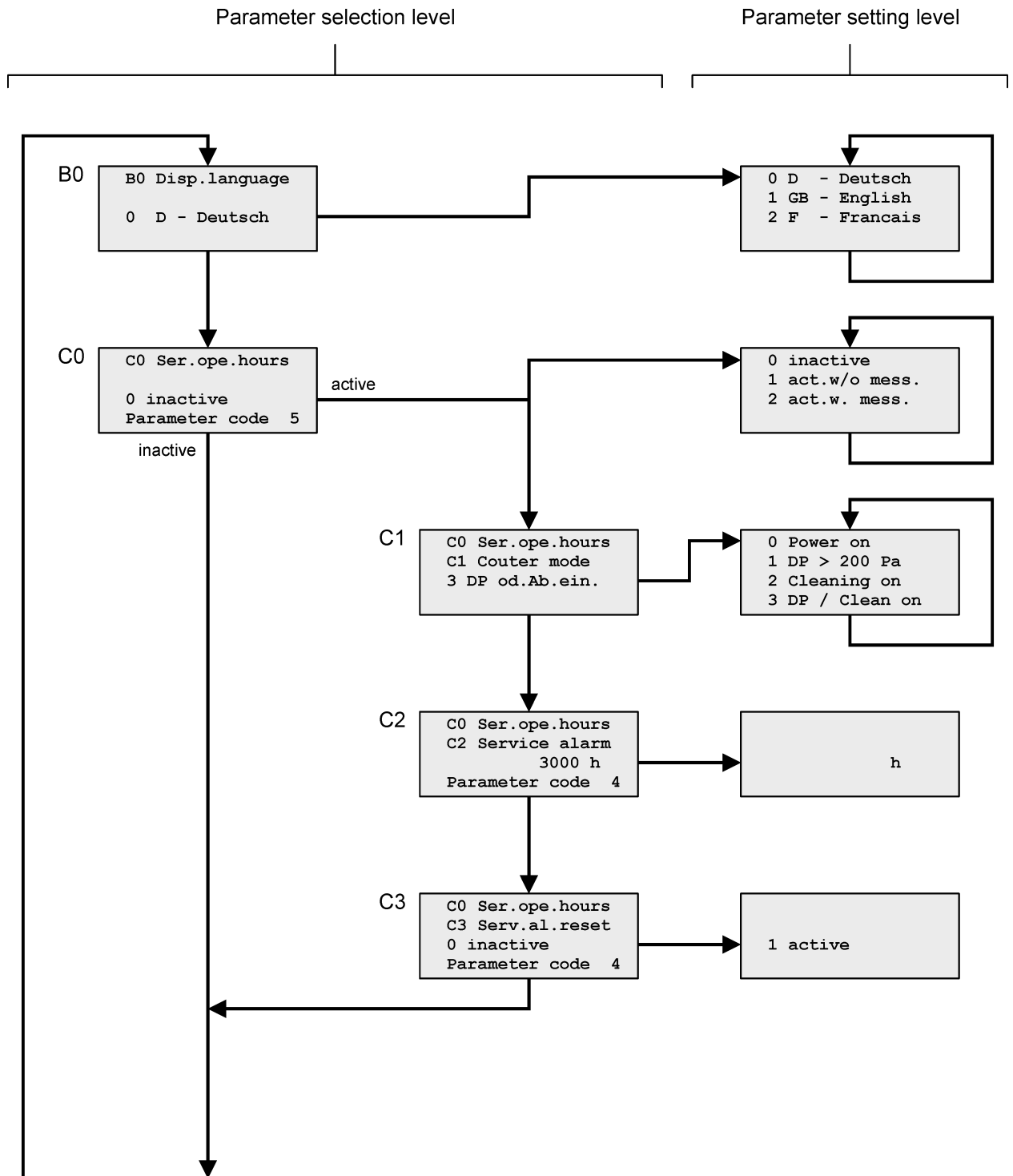

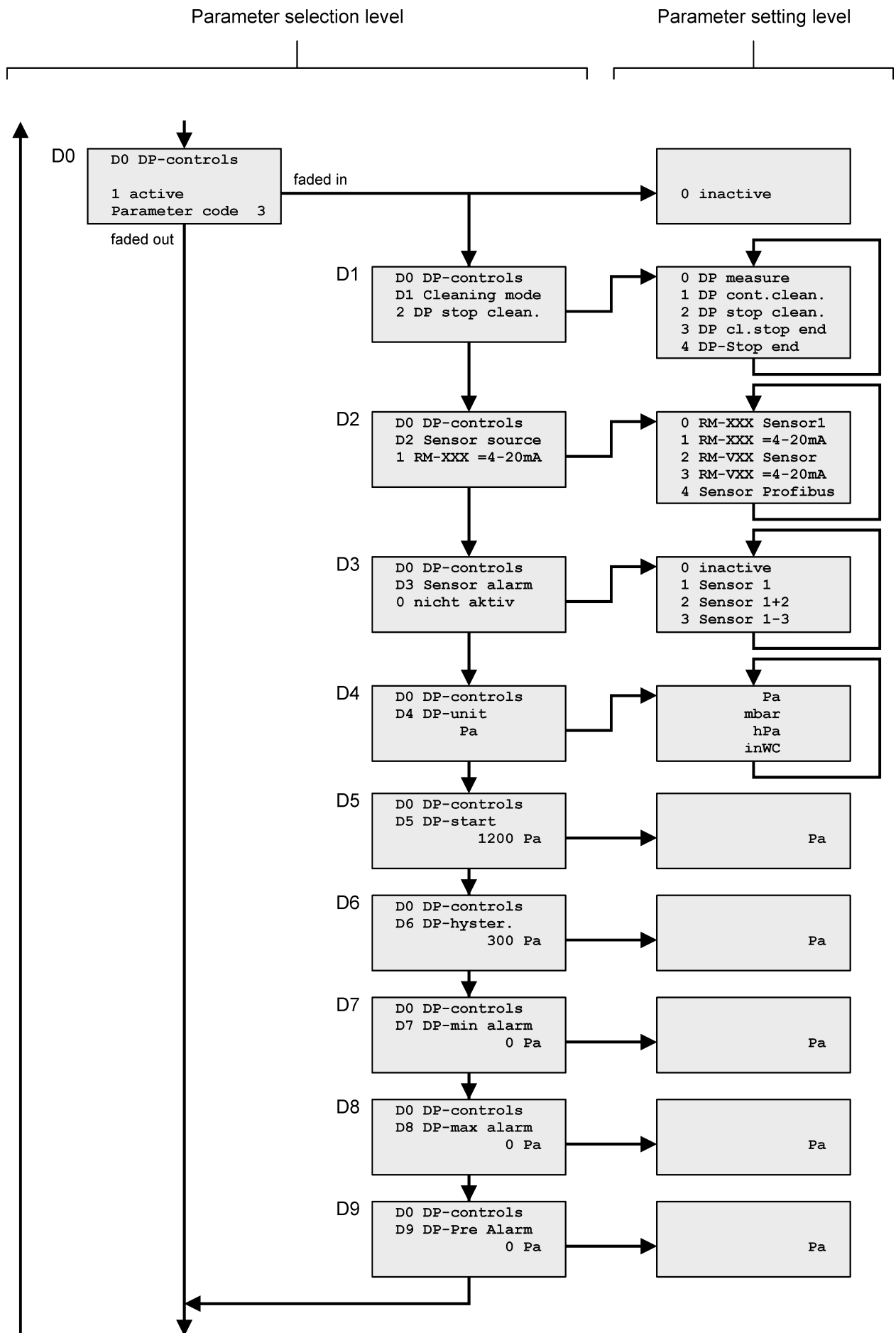

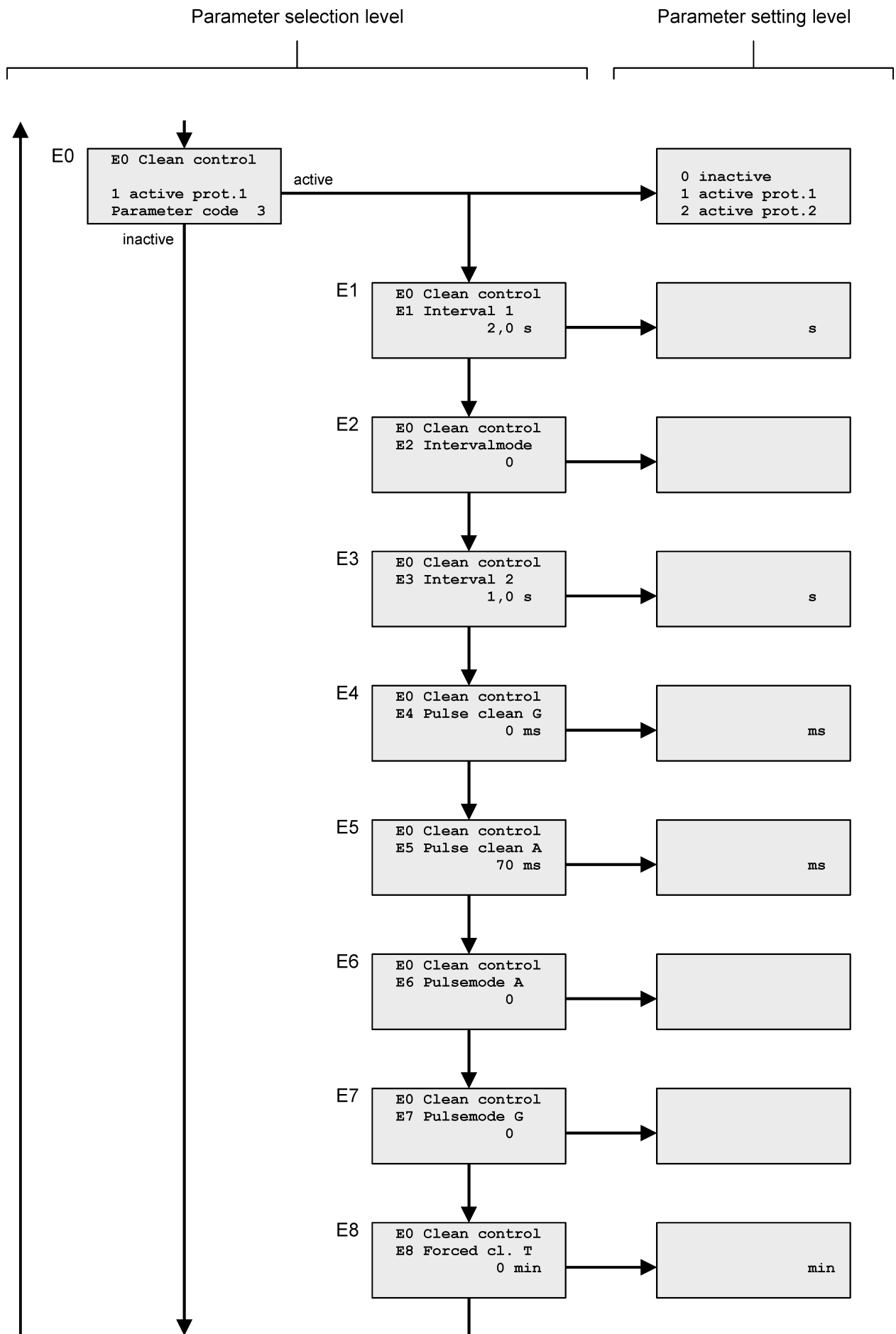

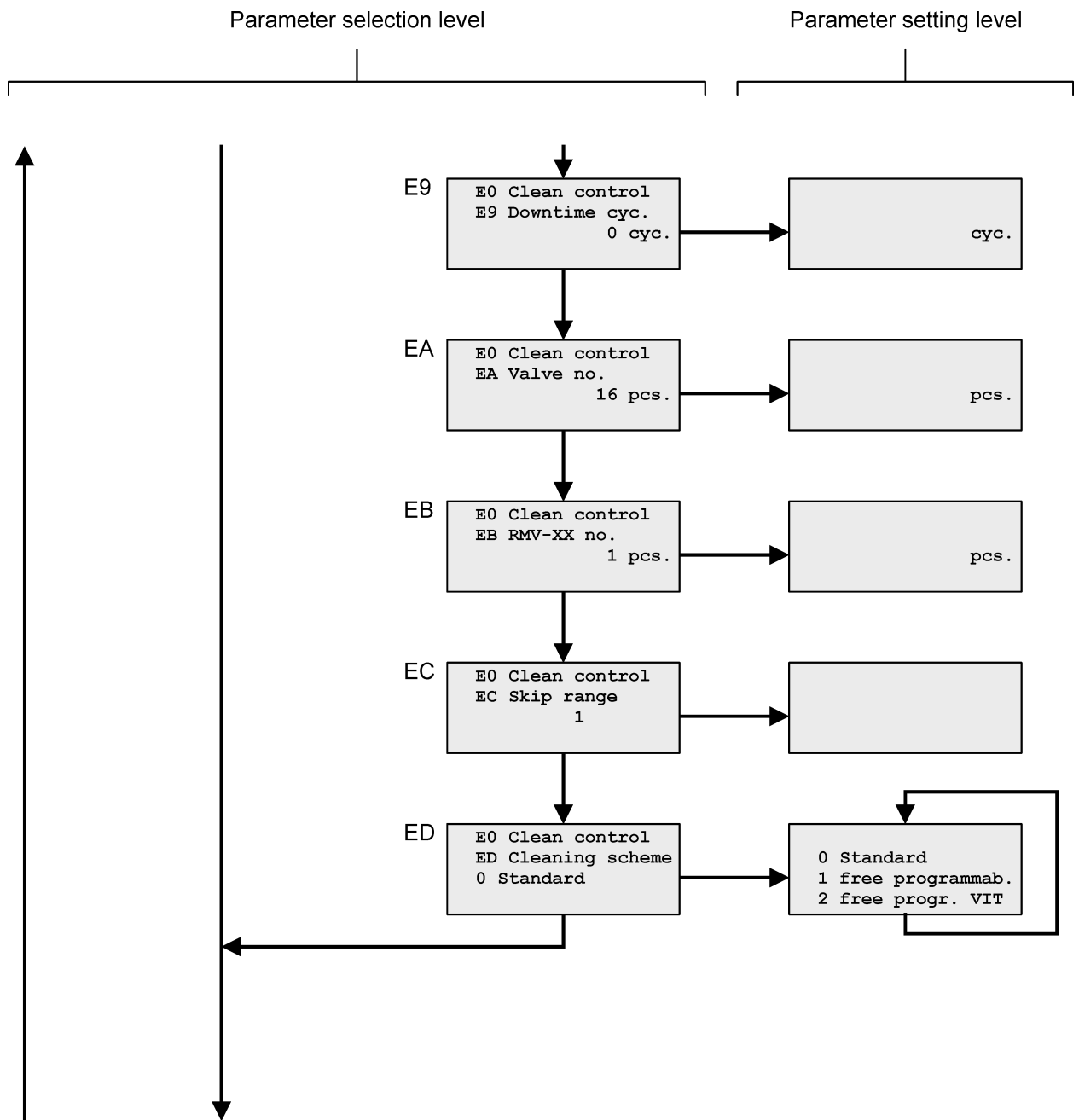

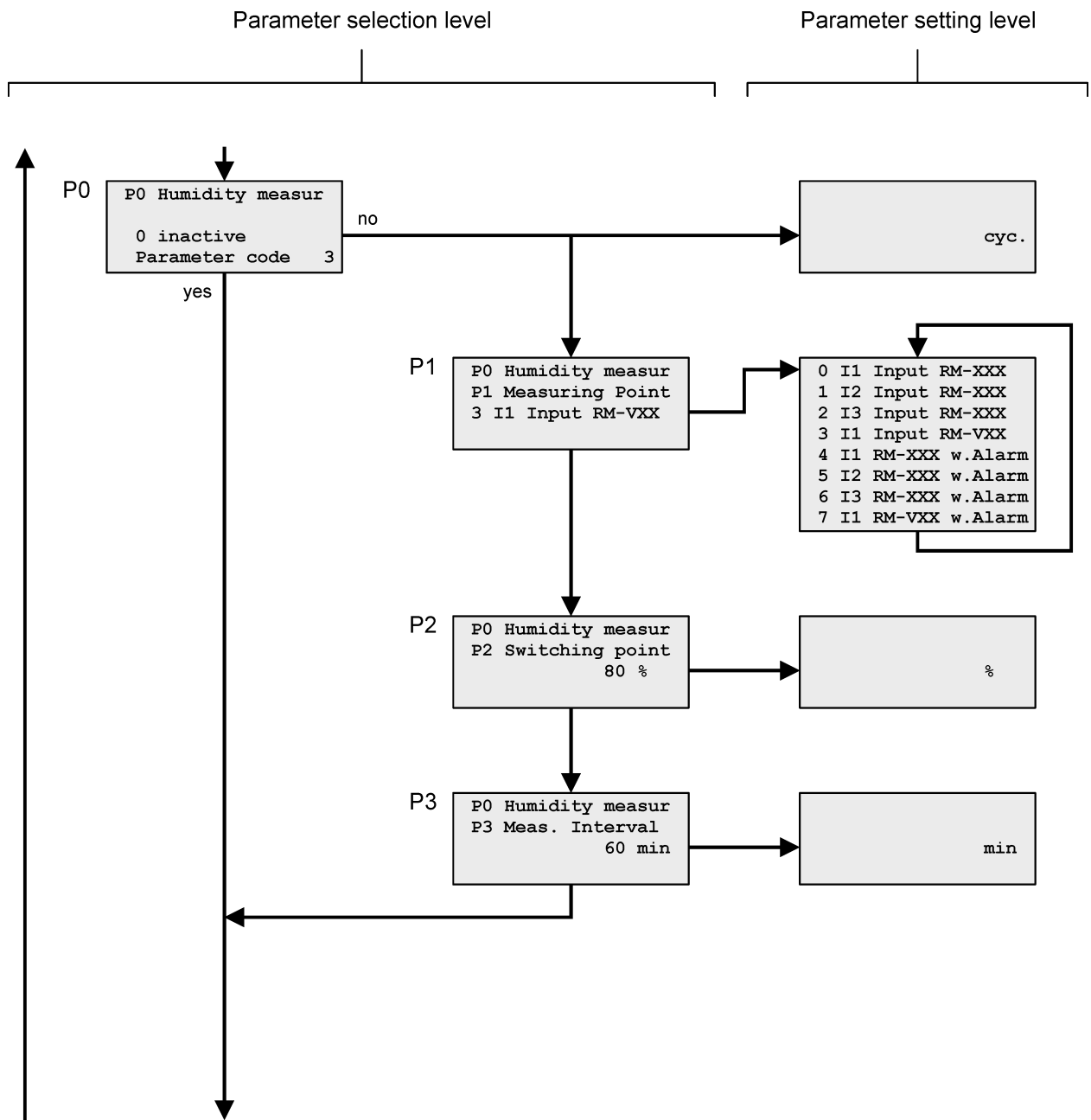

5.9 Parameter list

Parameter	Code 	Text in display, line 1	Meaning	Factory setting	Setting range	See page
B0	–	B0 Disp.language	Language of the display text	0	0 ... 2	21

Parameter block C0-C3 "Service operating hours counter"

C0	5	C0 Ser.ope.hours	Service operating hours counter	0 ¹	0 ¹ ... 2	21
C1	–	C1 Counter mode	Operating hours counter mode	3	0 ... 3	21
C2	4	C2 Service alarm	Service alarm	3000 h	0 ¹ ... 25.500 h	21
C3	4	C3 Serv.al.reset	Service alarm reset	–	–	21

Parameter block D0-D8 "Δp-controls"

D0	3	D0 DP-controls	Δp controls	1	0 ¹ , 1	22
D1	–	D1 Cleaning mode	Δp cleaning mode	2	0 ... 4	22
D2	–	D2 Sensor source	Sensor source	1	0 ... 4	22
D3	–	D3 Sensor alarm	Sensor alarm	0	0 ... 3	23
D4	–	D4 DP-unit	Δp unit in display	Pa	Pa, mbar, hPa, inch/Wc	23
D5	–	D5 DP-start	Δp start	1200 Pa	100 ... 4800 Pa	23
D6	–	D6 DP-hyster.	Δp hysteresis	300 Pa	100 ... 4700 Pa	23
D7	–	D7 DP-min alarm	Δp min. alarm	0 ¹ Pa	0 ¹ ... 4600 Pa	23
D8	–	D8 DP-max alarm	Δp max. alarm	0 ¹ Pa	0 ¹ ... 5000 Pa	23
D9	–	D9 DP pre-alarm	Δp-pre-Alarm max.	0 ¹ Pa	0 ¹ ... 5000 Pa	23

Parameter block E0-EC "Cleaning control functions"

▶ E0	3	E0 Clean control	Cleaning control functions	1	0 ¹ ... 3	24
I1	–	E1 Interval 1	Interval 1	2 s	0.5 ... 250 s	24
I2	–	E2 Interval Mode	Interval mode ²	0 ¹	0 ¹ ... 1	24
I3	–	E3 Interval 2	Interval 2	1 s	0.5 ... 250 s	24
I4	–	E4 Pulse clean G	"Gas valve" pulse time	0 ¹ ms	0 ... 990 ms	24
E5	–	E5 pulse clean A	Pulse time "Cleaning valve"	70 ms	40 ... 990 ms	24
I6	–	E6 Pulsemode A	Pulse mode "Cleaning valve" ³	0 ¹	0 ¹ ... 1	24

¹ 0 = Function inactive

² is not active with active impulse controller or with active Profibus function with protocol 1

³ is not active with active Profibus function with protocol 1

i

▶ Parameters must definitely be set before commissioning.

 Parameter code 3 = 4711

Parameter code 4 = known only to the manufacturer of the filter system

Parameter code 5 = known only to the manufacturer of the filter system

Parameter	Code 	Text in display, line 1	Meaning	Factory setting	Setting range	See page
I7	–	E7 Pulsemode G	Pulse time mode "gas valve" ³	0	0 ¹ ... 1	24
I8	–	E8 Forced cl. T	Compulsory cleaning time	0 ¹	0 ¹ ... 2500 min	24
E9	–	E9 Downtime cyc.	Downtime cycles	0 ¹	0 ¹ ... 64	24
▶ EA	3	EA Valve no.	Number of valves at parameter setting E0 = 1	16	1 ... 240	24
			Number of valves at parameter setting E0 = 2	16	1 ... 480	24
▶ EB	3	EB Number RM-VXX	Number of I/O modules RM-V8 or RM-V16 or with parameter setting E0 = 1	1	1 ... 15	25
			Number of I/O modules RM-V8.10 or RM-V16.10 or with parameter setting E0 = 2	1	1 ... 30	25
EC	3	EC Skip range	Cleaning skip range	1	1 ... EA/2 ⁴	25
ED	3	ED Clean.diagram	Cleaning diagram	0	0 ... 2	25

Parameter block P0-P3 "Humidity measurement"

P0	3	P0 Humidity measur	Humidity measurement	0 ¹	0 ¹ ... 3	26
P1	3	P1 Measuring Point	Measuring point	3	0 ... 7	26
P2	3	P2 Switching point	Switching point	80%	0 ... 100%	26
P3	3	P3 Meas. Interval	Measuring interval	120 min.	0 ... 500 min.	27

¹ 0 = Function inactive

³ is not active with active Profibus function with protocol 1

⁴ EA/2 = Set value of the EA parameter divided by 2

i ▶ Parameters must definitely be set before commissioning.

 Parameter code 3 = 4711

5.10 Parameter description and explanation of function

Parameter B0 "Display language"

The display texts can be shown in different national languages. The text output is in German when the system is delivered.

B0 =	Text in display, line 3	Meaning
0	0 D - Deutsch	Text output German
1	1 GB - English	Text output English
2	2 F - Francais	Text output French

Parameter block C0-C4 "Service operating hours counter"

Parameter C0 "Service operating hours counter"

The service operating hours counter can be activated or deactivated with parameter C0. The parameter value is factory-set to 0 (= inactive).

C0 =	Text in display, line 3	Meaning
0	0 inactive	The operating hours counter is deactivated. The parameters C1 through C3 are not displayed.
1	1 act.w/o mess.	The operating hours counter is activated but without external messages.
2	2 act.w. mess.	The operating hours counter is activated, with external service or alarm messages.

Parameter C1 "Operating hours counter mode"

The operating hours counter mode can be set with parameter C1.

C1 =	Text in display, line 3	Meaning
0	0 Power on	The counter counts when mains voltage is present.
1	1 DP > 200 Pa	The counter counts when the differential pressure is > 200 Pa.
2	2 Cleaning on	The counter counts when cleaning is activated.
3	3 DP /Clean on	The counter counts when the differential pressure is > 200 Pa or cleaning is activated.

Parameter C2 "Service alarm"

The service alarm switch point can be set with parameter C2. It is factory-set to 3000 hours. Once the counter reaches the set value the yellow LED is activated and signals a present warning to the operator. On the display, the service alarm message „Operating hours" appears.

Parameter C3 "Service alarm reset"

A maintenance technician can reset the operating hours counter for the service alarm to 0 with parameter C3. The present service alarm message is cleared and the yellow service LED switched off.

Parameter block D0-D8 “ Δp -controls“

Parameter D0 “ Δp -controls“

Parameters D1-D8 can be faded in or out with parameter D0. Parameter D0 is factory-set to 1. The " Δp control" is also active. If Δp control is not active, cleaning is set to the "continuous" mode.

D0 =	Text in display, line 3	Meaning
0	0 inactive	Parameters D1-D8 are faded out (invisible)
1	1 active	Parameters D1-D8 are faded in (visible)

Parameter D1 “ Δp Cleaning mode“

The operating mode of the differential pressure-dependent cleaning can be set with parameter D1.

D1 =	Text in display, line 3	Meaning
0	0 DP measure	The control only serves as differential pressure measuring device with all Δp alarm switch points.
1	1 DP cont.clean.	Cleaning works continuously independent from the differential pressure, with the parametrised control times (see parameters E1, E3, E5 and E9). The Δp alarm switch points set are active.
2	2 DP stop clean.	The dedusting works in start-stop mode. If the differential pressure reaches the start value set with parameter D5 cleaning is activated until the differential pressure falls below the value D5 - D6 (Δp start value minus Δp hysteresis value). The valve number selected last is stored to enable cleaning to continue with the subsequent valve when starting again.
3	3 DP cl.stop end	The dedusting works in the start-stop mode with circulation ending. If the differential pressure reaches the start value set with parameter D5, the valve number is stored and cleaning is activated until the differential pressure falls below the value D5 - D6 (Δp start value minus Δp hysteresis value) and the stored valve number is reached. (At least 1 complete circulation is always carried out.)
4	4 DP-Stop end	Cleaning works in stop-end mode. If the differential pressure reaches the Δp start value set by parameter D5 cleaning remains active until the differential pressure drops below the D5 - D6 (Δp start value minus Δp hysteresis value) and the last valve has been operated.

Parameter D2 “Sensor source“

The source of the differential pressure measurement is set with parameter D2.

D2 =	Text in display, line 3	Meaning
0	0 RM-XXX Sensor1	Δp measurement via sensor 1 of the RM-350 C
1	1 RM-XXX =4-20mA	Δp measurement via sensor I1 of the RM-350 C
2	2 RM-VXX Sensor	Δp measurement via the sensor of the I/O module RM-V8 or RM-V16 with the address No.1
3	3 RM-VXX =4-20mA	Δp measurement via the current input of the I/O module RM-V8 or RM-V16 with the address No.1
4	4 Profib.0-5000 Pa	Δp measurement via an external signal (determined from the Profibus input data)

Parameter D3 "Sensor alarm"

The RM-350 C indicates a sensor alarm when an evaluated sensor is faulty or the measuring hoses on the sensor are connected incorrectly. The sensors to be monitored are set with parameter D3.

D3 =	Text in display, line 3	Meaning
0	0 inactive	Sensor monitoring deactivated
1	1 Sensor 1	Monitoring of sensor 1
2	2 Sensor 1+2	Monitoring of sensors 1 and 2
3	3 Sensor 1-3	Monitoring of sensors 1, 2 and 3

Parameter D4 "Δp Unit"

The display unit of the differential pressure is set with parameter D4. It is factory-set to the unit Pascal (Pa).

Text in display, line 3	Meaning
Pa	Differential pressure display in Pa
mbar	Differential pressure display in mbar
hPa	Differential pressure display in hPa
inWC	Differential pressure display in inch/WC

Parameter D5 "Δp Start"

The Δp start value of the differential pressure-dependent cleaning is set with parameter D5.

Parameter D6 "Δp Hysteresis"

The Δp hysteresis value of the differential pressure-dependent cleaning is set with parameter D6.

Parameter D7 "Δp min. alarm"

The Δp min. alarm value is set with parameter D7.

Parameter D8 "Δp max. alarm"

The Δp max. alarm value is set with parameter D8.

Parameter D9 "Δp pre-alarm max."

Parameter D9 is used to set the Δp pre-alarm max. value.

Parameter block E0-E8 "Cleaning control functions"

Parameter E0 "Cleaning control functions"

Cleaning control functions can be activated or deactivated with parameter E0. The parameter value is factory-set to 0 (= active).

E0 =	Text in display, line 3	Meaning
0	0	The cleaning control functions are inactive
1	1	The cleaning control functions are active via RMV-XX control (I/O module RM-V 8 or RM-V 16).
2	2	The cleaning control functions are active via RMV-XX-SMD control (I/O module RM-V 8.10 or RM-V 16.10).
3	3	The cleaning control functions are active via Autel valve box.

Parameter E1 "Interval 1"

The period between two successive cleaning pulses can be set in 0.1-second increments via parameter E1.

Parameter E2 "Interval mode"

The parameter is factory-set to 0 and is therefore not active. With parameter setting E2 = 1 all intervals are multiplied with factor 10, **except** with active interval controller or the option "Profibus on with protocol 1".

Parameter E3 "Interval 2"

The period between two successive cleaning pulses can be set in 0.1-second increments via parameter E3 during downtime and forced cleaning.

Parameter E4 "Pulse time G" (gas valve)

The valve pulse G can be set in 10-millisecond increments with parameter E5. The parameter is factory-set to 0 and is therefore not active. If the parameter is set to a value greater than 0 the valves with even valve numbers are selected with "Pulse time G" and the valves with odd valve numbers with "Pulse time A". See also appendix 7 "Input and output signal parametrisation, special parameter".

Parameter E5 "Pulse time A" (cleaning valve)

Valve pulse time A can be set in 10-millisecond increments via parameter E5.

Parameter E6 "Pulse time mode A"

The parameter is factory-set to 0 and is therefore not active. With the parameter setting E6 =1 the pulse time of the cleaning valves is multiplied with factor 10 **except** with the option "Profibus on with protocol 1".

Parameter E7 "Pulse time mode G"

The parameter is factory-set to 0 and is therefore not active. With the parameter setting E7 =1 the pulse time of the gas valves is multiplied with factor 10 **except** with the option "Profibus on with protocol 1".

Parameter E8 "Forced cleaning time"

The parameter is factory-set to 0 and is therefore not active. The forced cleaning time is set via parameter E8. If cleaning is in the stopped state, a complete cycle is always cleaned after the set forced cleaning time has elapsed.

Parameter E9 "Downtime cycles"

The last run cycles can be set with parameter E9. Interval 2 is always active during downtime.

Parameter EA "Number of valves"

The number of dedusting valves connected to the filter system can be set with parameter EA.

Parameter EB "Number of I/O modules"

The number of I/O modules (RM-V 8 or RM-V 16) connected to the filter system can be set with parameter EB.

- i** A communication alarm is triggered if the number of the I/O modules detected at the controller start differs from the settings.

Parameter EC "Cleaning skip range"

In the delivery state the valves are selected in direct succession (1, 2, 3, 4 .../ skip range = 1). Depending on the filter arrangement cleaning in a different order may be useful (for example: 1, 4, 7, 10 ... / skip range = 3). The product discharge can be regulated this way. A cleaning skip range from 1 to 120 can be set with parameter EC. However, the value cannot be chosen greater than half the value of the number of valves set (parameter EA).

Parameter ED "Cleaning diagram"

With the parameter ED, the control can operate the valves in any possible cleaning sequence. For this, select the parameter ED and enter the code AB10. The display shows the first entry of the cleaning table.

Display	Meaning
Cleaning table	Row 1
Pul. 1> valve 1	Row 2 Pulse 1 is assigned to valve 1.
Con.no. 1	Row 3 Control number 1
Val.no. 1	Row 4 Valve output number 1

The displayed text has this meaning: Pulse 1 is assigned to valve 1 (row 2). This valve is connected to the I/O module RM-V8 / RM-V16 using the address 1 (row 3). The valve is connected to the output V1 of the I/O module (row 4).

Momentarily press the ∇ or \triangle key to display the remaining entries of the cleaning table one after the other (pulses 2 through 480). You can change the displayed assignment by pressing the ENTER key until the text "Pulse.tab.inp.-valv." appears in row 1 of the display. Press then the ∇ or \triangle key momentarily to increase or decrease the displayed valve number. If you set zero as valve number, the corresponding pulse is blanked and no valve is operated. Save your change by pressing the ENTER key until the text "Cleaning table" appears in row 1 of the display. Momentarily press the ∇ or \triangle key to display the remaining entries of the cleaning table one after the other. Once you have completed all changes in the cleaning table, press the \triangle and ∇ keys simultaneously until the displayed text changes to enter the operating mode.

To activate the saved cleaning table you have to set the parameter ED to the value "1".

ED =	Text in display, line 3	Meaning
0	0 Standard	The valve assignment corresponds to the setting in parameter EC.
1	1 free programmab.	The valve assignment is based on a cleaning table that is entered with the keyboard of the RM-350 C . See above.
2	2 free progr. VIT	As described under ED = 1, but with a programmed valve identification table that is stored in the factory. Not available in the standard product.

Parameter block P0-P3 "Humidity measurement"

Parameter P0 "Humidity measurement"

Parameter P0 can be used to activate / deactivate the humidity measurement and to set the number of cleaning cycles that are performed after the humidity switching point (parameter P2) has been exceeded and the measuring interval time (parameter P3) has been lapsed. The parameter value is factory-set to 0 (= inactive).

With activated humidity measurement and released control ("0" signal on input E1), the humidity in the filter is monitored. If the set humidity switching point (parameter P2) is exceeded and no cleaning is active, the cleaning cycles set in parameter P0 will be carried out after expiration of the measuring interval time (parameter P3). After that, the measuring interval time is counted again. With switched on cleaning, the measuring interval time is reset. Depending on the setting for parameter D1, a complete circulation is carried out for each cleaning cycle or the cleaning is active until the last valve is reached. If the cleaning is switched off externally, this command has top priority.

P0 =	Text in display, row 3	Meaning
0	0 inactive	The humidity measurement is inactive.
1	1 cyc	Number of executed cleaning cycles
2	2 cyc	Number of executed cleaning cycles
3	3 cyc	Number of executed cleaning cycles

Parameter P1 "Measuring point"

The analog input I3 of the RM-350 C controller is provided for the connection of the 4-20 mA signal from the humidity sensor. If this input is already assigned, you can use the parameter P1 to select a different free analog input to which the humidity sensor is to be connected.

P1 =	Text in display, row 3	Meaning
0	0 I1 Input RM-XXX	The humidity sensor must be connected to the analog input I1 of the RM-350 C.
1	1 I2 Input RM-XXX	The humidity sensor must be connected to the analog input I2 of the RM-350 C.
2	2 I3 Input RM-XXX	The humidity sensor must be connected to the analog input I3 of the RM-350 C.
3	3 I1 Input RM-VXX	The humidity sensor must be connected to the analog input I1 of the I/O module RM-V8 / RM-V16 using the address 1.
4	4 I1 RM-XXX w.Alarm	As described under P1 = 0, but with additional current monitoring (an alarm is issued if no input current flows $I < 1$ mA).
5	5 I2 RM-XXX w.Alarm	As described under P1 = 1, but with additional current monitoring (an alarm is issued if no input current flows $I < 1$ mA).
6	6 I3 RM-XXX w.Alarm	As described under P1 = 2, but with additional current monitoring (an alarm is issued if no input current flows $I < 1$ mA).
7	7 I1 RM-VXX w.Alarm	As described under P1 = 3, but with additional current monitoring (an alarm is issued if no input current flows $I < 1$ mA).

Parameter P2 "Switching point 1"

The humidity switching point in percent can be set by parameter P2. When the humidity switching point has been exceeded and the measurement interval time (parameter P3) has lapsed the cleaning cycles set with parameter P0 are executed. This parameter is factory-set to 80%.

Parameter P3 "Measuring interval"

The measuring interval time can be set from 2 to 500 minutes in 2-minute steps with the parameter P3. The measuring interval is the time that is counted from the moment of humidity switching point overshooting up to the start of the set cleaning cycles. Once the cleaning cycles have been executed, the measuring interval is counted again. Only after that, the signal from the humidity sensor is evaluated. This parameter is factory-set to 120 minutes.



Parameter groups J0-J5 and O0-O1
see appendix 1 "Cleaning monitoring"

Parameter group L0-L7
see appendix 2 "Cleaning pressure control"

Parameter group M0-M8
see appendix 3 "Cleaning pressure-related interval control"

Parameter block N0-N1
see appendix 4 "Profibus function, Profibus protocol"

Parameter group S0-S2
see appendix 5 "Sensor options"

Parameter group I0-I2
see appendix 6 "Analogue module options"

Parameter groups F0-F8, G0-G8, T0-T6 and U0-U1
see appendix 7 "Input and output signal parametrisation, special parameters"

Parameter R0-R5
see appendix 8 "Dust monitoring"

6 Operating modes

6.1 Time-controlled cleaning (parameter E1, E5, D1)

Cleaning takes place continuously with the control times E1, E5 set.

Interval 2 (E3) becomes active only in the event of downtime.

6.2 Forced cleaning (parameter E8)

If cleaning is in the stopped state, a complete cycle with interval 2 is always cleaned after the set forced cleaning time has elapsed. Forced cleaning is deactivated when the control is in stand-by or via an external signal.

6.3 Differential pressure-controlled cleaning (parameter D5, D6, D1)

Cleaning starts when the filter's differential pressure Δp has reached the "DP-Start" value. The solenoid valves are controlled sequentially. By cleaning the differential pressure drops after a certain period of time. Cleaning stops when the differential pressure has reached the value "DP-Start" minus "DP-Hyster."

i The differential pressure-controlled cleaning works as follows in Profibus mode:
Cleaning starts when the differential pressure has reached the Δp max. switch point. Cleaning stops when the differential pressure has dropped to the Δp min. switch point.

Interval 2 (E3) becomes active only in the event of downtime.

6.4 Downtime (parameter E9)

Downtime cleaning is started by the closing of contact connected to input E1. Downtime cleaning stops when the contact opens.

Set the number of downtime cycles with parameter E9. Interval 2 is always valid during downtime.

6.5 Cleaning skip range (parameter EC)

See section "Parameter EC, cleaning skip range on page 25 on this.

6.6 Individual cleaning diagram (parameter ED)

For details, see section "Parameter ED, cleaning diagram" on page 25.

6.7 Optional Profibus operation (parameter N0)

If parameter N0 and the Profibus control bit are set to the value 1 by byte 1, the RM-350 C filter control only works with the Profibus data (see section "Input data (30-byte working range)" in appendix 4 "Profibus function, Profibus protocol" on this). With protocol 1 the parameters of the RM-350 C are replaced by the Profibus parameters and then no longer impact the control functions. The inputs of the control are no longer active. With protocol 2, only the input and output signals are processed without impact of the control parameters.

i In the event of a Profibus malfunction the RM-350 C filter control works with its own parameters and the inputs of the controller are active.

6.8 Valve test mode

In the valve test mode, you can select an individual valve and operate it with the set control times (pulse and interval time 1). If the interval time 1 is set to a value smaller than 5 s, the test program works with a interval time of 5 s.

To activate the valve test mode select the parameter E0 and enter the code ABVT. The display shows a window for valve 1 of the controller (I/O module RM-V8 / RM-V16) with address 1.

Display	Meaning
V Test program	Row 1
----- bar --- %	Row 2
Ctrl. 1 Valve no. 1	Row 3
(+) End (+)	Row 4

* Only displayed with active pressure / dust monitoring.

After expiration of interval time 1, the displayed valve is operated. Momentarily press the ∇ key to select different valves of the control 1 in succession. With each operation of the ∇ key, the displayed valve is immediately activated. Momentarily press the \triangle key to select the remaining controls (I/O modules) in succession. You can stop the valve test mode by pressing the ENTER key.

7 Troubleshooting

Fault	Possible causes	Recommended action
The "ON" LED does not light	No mains voltage	Check the power supply
	Fuse in device defective	Replace fuse
	System EMERGENCY-STOP actuated	Check EMERGENCY-STOP
No valve activity	Wiring to valves interrupted	Check cables and electrical connections
	Solenoid defective	Replace coil
	Cycle interrupted	<ul style="list-style-type: none"> - Check hose connections - Check parameter groups D and E
No downtime cleaning	Parameter E9 = 0 (downtime cycles)	Check parameter E9 "Downtime cycles"
	Contact on input E1 does not open	Check contact on input E1
Cleaning not effective	Interval too long	Set parameter E1 "Interval 1" to lower value
	Pressure too low	<ul style="list-style-type: none"> - Increase pressure - Set parameter E1 "Interval 1" to higher value
	Valve defective	Check / replace valves
	Pulse time too short	Set parameter E5 "Pulse time" to higher value
	Cycle frequently interrupted	Check differential pressure transmitter and hose connections
Differential pressure display error	Hose connection error	<ul style="list-style-type: none"> - Drain hoses. Clean hose connection points on the filter housing with compressed air (only in direction of filter, never in direction of sensor) - Install hoses without kinks - Check hose connections in the device for water, kinks, etc.
The display shows the message „RM-VXX Comm.Alarm" (communication alarm).	The number of connected I/O modules RM-V8 / RM-V16 does not agree with the parameter setting.	<ul style="list-style-type: none"> - Check the EB parameter setting and correct if necessary - Check bus connection for polarity and electrical connection. - Check address setting of the I/A modules.

Fault	Possible causes	Recommended action
On the display, the message „RM-VXX alarm setting" appears.	The valve setting of the I/O modules RM-V8 / RM-V16 does not agree with the setting of the RM-350 C.	Check the EA parameter setting and correct if necessary
On the display, the message „Sensor alarm" appears.	Δp sensor DP-1, DP-2 or DP-3 defective	Check the Δp sensors and replace if necessary
	Δp measuring lead connected incorrectly or defective	<ul style="list-style-type: none"> - Check connections of the Δp measuring leads and replace if necessary - Check Δp measuring leads and replace if necessary
On the display, the message „Input lx alarm" appears.	The input current of the analogue input is too low.	Check analogue line for polarity and electrical connection.

8 Text messages on the display

In the operating mode of the filter control RM-350 C the following operating messages are either displayed directly or they can be retrieved in sequence by pressing the Δ key or the ∇ key. Non-active functions are not displayed.

i If no key is pressed during a duration of 3 minutes the display automatically returns to operating message 1.

8.1 Program start

Display	Meaning
<pre> Program RM-3X0C xxx.xxx.xxx Version no. x Date: xx.xx.20xx </pre>	The name of the program, the version number and the date of the program release are displayed for approx. 4 seconds after switching on the supply voltage. The device powers up during this time and conducts a self-test.

8.2 Operating message 1

Display	Meaning
<pre> Stand-By </pre>	Row 1 The control is <u>not</u> released and the Profibus is <u>not</u> active.
<pre> Only DP measurement DP-contr. deactive DP filter #### Pa </pre>	Row 1 Parameter D1 is set to 0. Row 2 Parameter D0 is set to the value 0. Row 2 #### currently measured differential pressure of filter
<pre> Clean.contr.inactive DP-contr. deactive DP filter #### Pa </pre>	Row 1 Parameter E0 is set to the value 0. Row 2 Parameter D0 is set to the value 0. Row 2 #### currently measured differential pressure of filter
<pre> Ext.cleaning off </pre>	Row 1 The control is <u>not</u> released via the Profibus. The input "Cleaning off" carries 1-signal at factory setting. * The function of the inputs can be individually set via parameter group F0-F8. See appendix 7 "Input and output signal parametrisation, special parameters" on this.
<pre> Downtime active </pre>	Row 1 The downtime is active. Downtime is not externally released when the indicator flashes.

Display		Meaning
Ext.cleaning on	Row 1	The input "Cleaning on" carries 1-signal at factory setting. * The function of the inputs can be individually set via parameter group F0-F8. See appendix 7 "Input and output signal parametrisation, special parameters" on this.
Cont. cleaning on	Row 1	Control released and continuous cleaning on.
F-clean.in 5 min	Row 1	Start of active forced cleaning in 5 minutes
Forced cleaning on	Row 1	Cleaning is activated after the forced cleaning time has elapsed.
Cleaning on	Row 1	Cleaning has been activated because the rising differential pressure of the filter has reached the value „DP Start“.
Cleaning off	Row 1	Cleaning has been deactivated because the dropping differential pressure of the filter has reached the value „DP Start“ minus „DP Hyster.“. With the indicator flashing when the release of cleaning has been requested but not granted (see parameter Fn = 10/30 or Gn = 6/38).
		The following is displayed in rows 3 and 4 in all operating modes except in downtime:
Filter valv.no.###	Row 3	The cleaning valve with the filter number ### is active. Location: Control number ## / Control valve number ###
Ctrl.## Valv.no.###	Row 4	
DP-Filter ##### Pa	Row 2	##### effective measured differential pressure of the filter or parameter D0 is set to the value 0.
DP-contr. deactive	Row 2	
2	Row 2	The controller is in the 2nd downtime cycle.

8.3 Operating messages 2 to 4

Operating messages 2 to 4 are the currently valid parameter values. Row 1 specifies whether the control operates with the internal or the Profibus parameters. The effective differential pressure is displayed only when parameter D0 " Δp control" is set to value 1 (active).

Display		Meaning
Operating message 2		
DP-Min Al. ##### Pa	Row 2	##### set value Δp -Min Alarm
DP-Max Al. ##### Pa	Row 3	##### set value Δp -Max Alarm
DP Pre-Al. ##### Pa	Row 3	##### set value Δp -pre-alarm*
DP filter ##### Pa	Row 4	##### currently measured differential pressure of filter
* The operating message is displayed only when the parameter D9 Δp pre-alarm is set to a value greater than 0 (alternating at 3-second cycle with the value set for Δp Max. alarm).		
Operating message 3		
DP-Start 1200 Pa	Row 2	Parameter "Starting cleaning"
DP-Stop 900 Pa	Row 3	Parameter "Stopping cleaning"
DP-Filter ##### Pa	Row 4	##### currently measured differential pressure of filter
Operating message 4		
Interv.t. ##, # s	Row 2	##, # effective value of interval
Pulse t. ### ms	Row 3	### effective value of pulse time
Downtime ## cyc.	Row 4	## effective value of downtime cycles*
DP-Filter ##### Pa	Row 4	##### currently measured differential pressure of filter
* The operating message is displayed only when downtime is active. If downtime is not active, the currently measured differential pressure of the filter is displayed instead.		

8.4 Operating message 5 – only with active service operating hours counter

Display		Meaning
Next service	Row 1	Next service
* ##### h	Row 2	##### Time to next service
The asterisk symbol at the beginning of the row flashes when the service operating hours counter is active.		
Operating hours	Row 3	Elapsed general operating hours (mains on)
##### h	Row 4	#####

8.5 Operating message 6 – with activated humidity measurement only

Display	Meaning
<pre>Rel.Humidity Filter act. 0,0 % swp.1 80,0 %</pre>	Row 2 Relative humidity within the filter Row 3 Current measurement in percent Row 3 Set switching point 1 Row 4

8.6 Service and alarm messages

The service and alarm messages are shown in the first row. If several messages are present, the other messages can be retrieved in sequence by pressing the Δ key or the ∇ . The two lower rows also indicate the current operating message and the alarm condition.

The alarm messages are acknowledged by pressing the ENTER key or via the external acknowledgement input. With the "Profibus" option this can be done in addition via Profibus acknowledgement.



The service message can only be acknowledged via parameter C3 "Service alarm reset".

Display	Meaning
	Service message (the yellow "SERVICE" LED is lit at the same time)
<pre>Rem. oper. hours</pre>	Row 1 The set service operating hours have been reached
	Alarm messages (the red "ALARM" LED is lit at the same time)
<pre>DP-Min Alarm DP-Filter ##### Pa DP-Min Al. ##### Pa</pre>	Row 1 Δp -Min Alarm Row 2 ##### currently measured differential pressure of filter Row 3 ##### set value Δp -Min Alarm The differential pressure of the filter has dropped below the set value Δp min. alarm.
<pre>DP-Max Alarm DP-Filter ##### Pa DP-Max-Al. ##### Pa</pre>	Row 1 Δp -Max-Alarm Row 2 ##### currently measured differential pressure of filter Row 3 ##### set value Δp -Max Alarm The differential pressure of the filter has dropped below the set value Δp max. alarm.
<pre>DP pre-alarm DP-Filter ##### Pa DP-pre-Al. ##### Pa</pre>	Row 1 Δp -pre-Alarm Row 2 ##### currently measured differential pressure of filter Row 3 ##### set value Δp -pre-alarm* The differential pressure of the filter has dropped below the set value Δp pre alarm.

Display		Meaning
Cleaning Alarm Valve current No pressure No drop in pressure Filter valv.no. ### Ctrl.## Valv.no. ### R33HTE21AA050050UVC	Row 1	Cleaning Alarm
	Row 2	No valve current present or
	Row 2	cleaning pressure too low or
	Row 2	no pressure drop after a cleaning pulse
RM-VXX comm.alarm RM-VXX No. ## No reply	Row 3	on the valve with the filter number ###
	Row 4	Location: I/O module RM-V8 or RM-V16 with the control number/address ## and the control valve No. ### (valve connection faulty or valve defective). Optionally, the system valve ID number can be displayed.
	Row 1	RM-V8 / RM-V16 Communication alarm
	Row 2	Empty row
RM-VXX alarm setting RM-VXX Valve setting incorrect	Row 3	I/O module RM-V8 / RM-V16 with the address #
	Row 4	sends no response
	Row 1	RM-V8 / RM-V16 Setting alarm
	Row 2	The valve setting of the I/O modules RM-V8 / RM-V16 does not agree with the setting of the RM-350 C.
Sensor alarm # DP-Sens.defect or Check P-connection	Row 3	
	Row 4	
	Row 1	Sensor Alarm #
	Row 2	Δp -Sensor # defective or
Input Ix alarm I < #, # mA or not connected	Row 3	Δp -Connections faulty (check!)
	Row 4	
	Row 1	Input current monitoring
	Row 2	Input current Ix < #, # mA
Cl. press. min alarm PV-Min #, ## bar DP-PV-Min #### Pa DP-Filter #### Pa	Row 3	x = input 1, 2 or 3
	Row 4	#, # = 1.00 or 3.50 mA
	Row 1	Cleaning pressure Min. alarm*
	Row 2	The set-point has been reduced to the value PV Min and the current differential pressure Δp filter has dropped below the value Δp -PV Min for a period longer than the parametrised alarm time.
Cl. press. max alarm PV-Max #, ## bar DP-PV-Max #### Pa DP-Filter #### Pa	Row 3	
	Row 4	
	Row 1	Cleaning pressure Max. alarm*
	Row 2	The set-point has been increased to the value PV Max and the current differential pressure Δp filter has risen above the Δp -PV max value for a period longer than the parametrised alarm time.
Humidity sensor Al. I < 1,0mA or not connected	Row 3	* The alarm is automatically acknowledged when the condition triggering the alarm no longer exists.
	Row 4	
	Row 1	Humidity sensor alarm
	Row 2	Input current smaller than 1 mA or
		* The alarm is automatically acknowledged when the condition triggering the alarm no longer exists.
		not connected.
		<p>i In case of a fault, this alarm message will only be displayed if the parameter P1 is set to the value "4", "5", "6" or "7".</p>

9 Glossary

Term	Meaning
Acknowledge alarm	Clearing a stored alarm message.
Cleaning	Cleaning the filter elements with compressed air pulses
Cleaning Alarm	Alarm triggered in case of faulty cleaning.
Cleaning valve	Solenoid valve controlling the cleaning of the filter elements.
Communication alarm	Alarm which signals that the communication between the controller and a module or several modules via the bus system is faulty.
Compressed air pulse cleaning	Cleaning of the filter elements through compressed air pulses
Control parameters	The internal parameters of the RM-350 C filter control. In Profibus mode they are replaced by the Profibus parameters.
Differential pressure	Difference of the pressure Δp on the clean and raw gas side of the filter.
Differential pressure transmitter	Differential pressure sensor (Δp sensor) or transducer
Display language	Language in which the text messages are shown in the display.
Downtime cleaning (short: Downtime)	Cleaning of the filter elements after a shutdown of the system for a set duration or number of cycles.
Downtime cycles	The number of cleaning cycles carried out during downtime cleaning.
DP cleaning mode	Manner of functioning of differential pressure-dependent cleaning
DP hysteresis	If during cleaning the differential pressure drops below the value "DP Start minus DP Hysteresis" cleaning stops when Δp cleaning mode 2 or 3 has been selected.
DP max. alarm	Differential pressure where an alarm is triggered when exceeded.
DP min. alarm	Differential pressure where an alarm is triggered when fallen below.
DP start	If the rising filter differential pressure (Δp filter) reaches the set value "DP-Start" cleaning is started when Δp cleaning mode 2 or 3 has been selected.
DP stop	If the dropping filter differential pressure (Δp filter) reaches the value "DP Stop = DP Start minus DP Hysteresis" the running cleaning process is stopped when the Δp cleaning mode 2 or 3 has been selected.
I/O module	Module for the input and output of control signals
Interval (also interval time)	Time between two consecutive control pulses of the valve outputs during ongoing cleaning.
Operating level	Condition of the RM-350 C in which the device is operational.
Parameter block	Grouping of parameters relating to the same function.
Parameter code	Code that must be entered on the device to clear locked parameters.
Parameter selection level	State of the RM-350 C in which the operator of the device can select a parameter.
Parameter setting level	State of the RM-350 C in which the operator of the device can set a parameter.

Term	Meaning
Parameterisation mode	State of the RM-350 C in which the operator can parametrise the device (the RM-350 C is at the parameter selection or parameter setting level).
Profibus module	Module of RM-350 C control system converting the Profibus data into internal control data.
Profibus parameters	Parameters replacing the internal parameters of the RM-350 C filter control as Profibus data.
Pulse time	Duration of a control pulse of the valve outputs
R-IMC-BUS	Data bus system of RECO with special BUS protocol (RECO Inter Module Communication Protocol)
Sensor alarm	Alarm triggered when a faulty sensor signal is present.
Service alarm	Alarm triggered when the operating hours (parameter C2) set for the service interval have been reached.
Service operating hours counter	Depending on the mode set (parameter C1) the internal service operating hours counter is activated. The service alarm is triggered when the set operating hours (parameter C2) have been reached.
Solenoid valve	(also pilot valve) electromagnetically operated valve for the pneumatic selection of the diaphragm valves of the filter. The diaphragm valves, in turn, release the compressed air pulses for filter cleaning.

10 Technical specifications

Item	Data
Supply voltages	Device version 110 / 230 V AC: 110 V AC -10 % / +10 % 230 V AC -10 % / +10 %
	Device version 24 V DC: 24 V DC -0 % / +30 % i It is recommended not to choose the supply voltage below 28 V DC. Depending on the cable length and power consumption the valve voltage is otherwise too low.
Connected load	Design version 110 / 230 AC: max. 36 VA
	Device version 24 V DC: max. 36 W
BUS	R-IMC-Bus / Profibus
Signal inputs, digital	8 optocoupler inputs i The circuitry can either involve the internal control's 24 V DC or the external voltage of 24 V DC (see chapter 4 at ) "Connection of digital inputs E1 ... E8, 24 V DC")
Signal inputs, analog	3 inputs 4-20 mA, burden 250 Ω
Signal outputs	4 relay outputs, potential-free max. 2 A, 250 V or 1 A, 30 V DC
Fuse	Device version 110 / 230 V AC: T 0.4 A, 250 V, 5 x 20 mm
	Device version 24 V DC: T 2.5 A, 250 V, 5 x 20 mm
Temperature range	-20 °C to +60 °C
Protection class	Housing IP66 / NEMA 4
Dimensions	Width x Height x Depth 250 x 160 x 90 mm
Weight	approx. 0.8 kg
Altitude	Max. 3000 m above sea level

Disclaimer

The contents of this documentation have been verified for correctness and completeness. Nevertheless, errors can not be excluded so that we cannot guarantee the correctness of this information. Subject to alterations at any time.