



# MT

*ELECTRIC MOTORS*

1

## TECHNICAL CATALOGUE

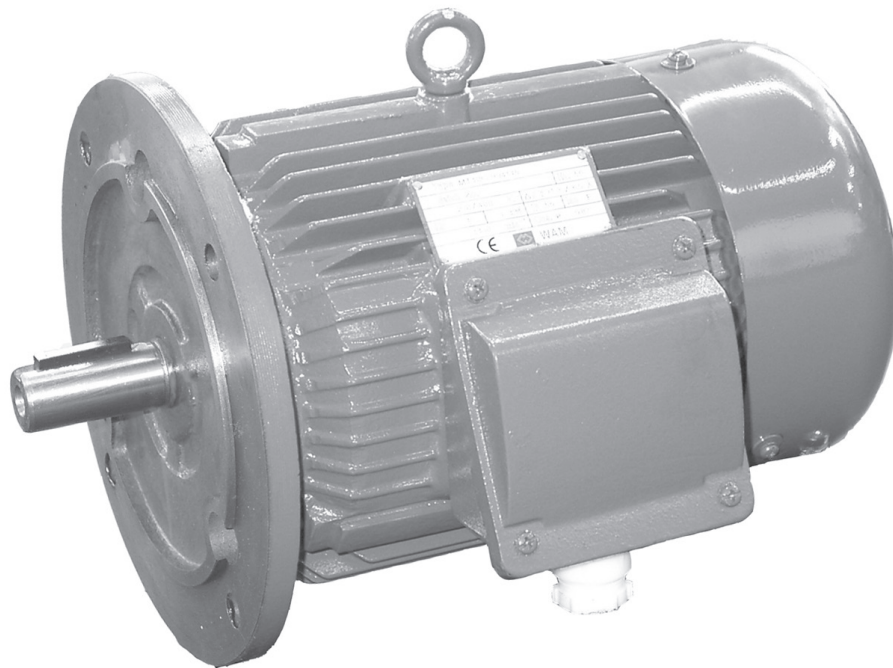

Manual No. CON.MT.--.T.A.1017.EN Issue: A  
Latest Update: October 2017

ORIGINAL INSTRUCTIONS IN ENGLISH

**WAMGROUP S.p.A.**  
Via Cavour, 338  
I-41030 Ponte Motta  
Cavezzo (MO) - ITALY

☎ + 39 / 0535 / 618111  
fax + 39 / 0535 / 618226  
e-mail [info@wamgroup.com](mailto:info@wamgroup.com)  
internet [www.wamgroup.com](http://www.wamgroup.com)





All the products described in this catalogue are manufactured according to **WAMGROUP S.p.A. Quality System procedures**. The Company's Quality System, certified in July 1994 according to International Standards **UNI EN ISO 9002** and extended to the latest release of **UNI EN ISO 9001**, ensures that the entire production process, starting from the processing of the order to the technical service after delivery, is carried out in a controlled manner that guarantees the quality standard of the product.

**This publication cancels and replaces any previous edition and revision.  
We reserve the right to implement modifications without notice.  
This catalogue cannot be reproduced, even partially, without prior written consent by the Manufacturer.**

**SUMMARY**

<b>1.0</b>	TERMINOLOGY .....	1
<b>2.0</b>	INTRODUCTION .....	2
<b>2.1</b>	General design features .....	2
<b>2.2</b>	Technical features .....	3
<b>2.3</b>	Operating conditions .....	3
<b>3.0</b>	REFERENCE STANDARDS .....	4
<b>4.0</b>	DESCRIPTION .....	5
<b>4.1</b>	Modular key .....	5
<b>5.0</b>	IE1 MOTORS .....	6
<b>5.1</b>	Overall dimensions of IE1 Efficiency class WAM electric motors .....	6
<b>5.2</b>	Electro-mechanical features of IE1 Efficiency class WAM electric motors .....	9
<b>6.0</b>	IE2 MOTORS .....	16
<b>6.1</b>	Overall dimensions of IE2 Efficiency class WAM electric motors .....	16
<b>6.2</b>	Electro-mechanical features of IE2 Efficiency class WAM electric motors .....	19
<b>7.0</b>	IE3 MOTORS .....	23
<b>7.1</b>	Overall dimensions of IE3 Efficiency class WAM electric motors .....	23
<b>7.2</b>	Electro-mechanical features of IE3 Efficiency class WAM electric motors .....	26
<b>8.0</b>	TECHNICAL FEATURES .....	30
<b>8.1</b>	Other technical features .....	30
<b>8.2</b>	Voltage variations .....	31
<b>8.3</b>	Operation of motors with wound rotors for 50Hz and use at 60Hz .....	31
<b>8.4</b>	Duty type .....	32
<b>8.5</b>	Variation of the nominal power depending on the operation conditions .....	33
<b>8.6</b>	Insulation class .....	34
<b>8.7</b>	IP Protection degree .....	35
<b>8.8</b>	Bearings .....	36
<b>8.9</b>	Thermistors .....	36
<b>8.10</b>	Permitted axial and radial loads .....	38
<b>8.11</b>	Motor output shaft (with A-Shaped key) .....	39
<b>A</b>	ATTACHMENTS .....	41
<b>A1</b>	Declaration of incorporation .....	41

**1.0 TERMINOLOGY**

<b>Cs</b>	Locked rotor torque	[Nm]
<b>Cn</b>	Rated torque	[Nm]
<b>Cmax</b>	Maximum torque	[Nm]
<b>Is</b>	Locked rotor current	[A]
<b>In</b>	Rated current	[A]
<b>Cs/Cn</b>	Locked rotor torque/rated torque	/
<b>Cmax/Cn</b>	Maximum torque/rated torque	/
<b>Is/In</b>	Locked rotor current/rated current	/
<b>Pn</b>	Rated power kW	[W] - [kW]
<b>Pe</b>	Electric power	[W] - [kW]
<b>Pm</b>	Mechanical power	[W] - [kW]
<b>V</b>	Voltage	[V]
<b>I</b>	Current	[A]
<b>F</b>	Frequency	[Hz]
<b>n</b>	RPM	[r/min]
<b>J</b>	Moment of inertia	[kg/m <sup>2</sup> ]
<b>C</b>	Twisting moment	[Nm]
<b>T</b>	Temperature	[° C]
<b>ΔT</b>	Temperature difference	[K]
<b>Fr</b>	Permitted radial force	[N]
<b>Fa</b>	Permitted axial force	[N]
<b>η</b>	Efficiency	/
<b>cos φ</b>	Power factor	/
<b>S</b>	Slip	/

All products described in this manual have been manufactured according to the operating methods defined by the WAMGROUP S.p.A. Quality System.

The Company's Quality System, certified since July 1994 in conformity with International Standards UNI EN ISO 9002-94 and subsequently extended to International Standards UNI EN ISO 9001/ 2000, ensures that the entire production process - from the order to after-sales service - is carried out in a controlled manner, able to ensure the product quality compliance to the standard.

The electric motors made by WAM are manufactured according to the international standards IEC, to the European CENELEC standard and various other standards such as VDE/DIN CEI NFC and BS.

## 2.1 General design features

- Three-phased asynchronous induction motor of the closed type with outer surface ventilation.
- Rotor and squirrel cage made from aluminium or die-cast aluminium alloy.
- Casing made from cast-iron; the material has been selected for its high mechanical resistance and anti-corrosive features (also available in aluminium up to a size 132), with lifting rings for sizes greater than 112.
- Prearranged for ground terminal placed inside the terminal compartment.
- The sealing gasket of the junction box is made from black NBR. The cable glands installed have metric pitch with protection degree IP65 (EN62444).
- The shaft is made from C45 steel. The shaft ends have threaded holes at the top, with dimensions and depth in accordance with UNI 9321 standard.
- The output end and tab are standardized in accordance with IEC72-1, the tabs are in a hollow cavity in accordance with UNI EN 6604-A.
- The cooling fan, made from thermoplastic material, consists of radial blades to allow ventilation of motors in both directions of rotation.
- The bearings used are of the ball type with double protection screen, pre-lubricated with grease and do not require maintenance.
- The junction box is located on the upper side or on the left side of the motor, seen from the housing.

## 2.2 Technical features

- Standard power 0.12 to 200 kW
- Structural configuration: B5, B14 and B3
- Multi-frequency motors 50-60 Hz
- Voltage for 50 Hz: 220/240 (Δ)/ 380/420 (Y)\_380/420 (Δ) - 660/725 (Y)
- Voltage for 60 Hz: 250/280 (Δ)/ 440/480 (Y)\_440/480 (Δ) - 756/836 (Y)
- 2, 4 or 6 poles and double polarity 4\_8 poles
- Junction box protection IP55
- Plastic cable gland IP65
- Protection index IP55
- Dimensions and height of standard axes
- External cooling by means of fan
- Insulation class: F
- All WAM electric motors have PTC thermistors.
- Voltage by motors size  $\leq 132$ 
  - 220/240 V(Δ) - 380/420 V(Y) a 50 Hz
  - 250/280 V(Δ) - 440/480 V(Y) a 60 Hz
- Voltage by motors size  $\geq 160$ 
  - 380/420 V(Δ) - 660/725 V(Y) a 50 Hz
  - 440/480 V(Δ) - 756/836 V(Y) a 60 Hz
- Voltage of motors used in South America having the size  $\leq 132$ 
  - 210/230 V(Δ) - 360/400 V(Y) a 60 Hz
- Voltage of motors used in South America having the size  $\geq 160$ 
  - 360/400 V(Δ) - 630/690 V(Y) a 60 Hz

### 4/8 Poles motors

- Dahlander single winding
- Rotation speed  $\approx 1450 / 730$  rpm
- Single Voltage
  - 380-420 V a 50 HZ
  - 440-480 V a 60 Hz

## 2.3 Operating conditions

- The electric motors manufactured by WAM withstand humidity levels up to 90% and can work at environmental temperatures varying from  $-10^{\circ}$  to  $+40^{\circ}$ .

Normal used under 1000m a.s.l.

**N.B.:** The motors manufactured to operate at frequency 50Hz can be powered by 60 Hz voltage (also by keeping the same voltages relative to 50Hz); in this case, the motor rated values such as power, speed, rated power and efficiency will obviously change.



### Important

**The IE2 motors referred to within the 2009/640/CE Directive if used within the European Economic Area have to be exclusively powered by means of an inverter under the sole responsibility of the purchaser.**

**3.0 REFERENCE STANDARDS**

The motors manufactured by WAM® are compliant to the reference standards listed in the table below.

	-	EU	I	GB	FR	D	E
Name	IEC	CENELEC	CEI-UN-EL	BS	NFC	DIN-VDE	UNE
Rotary electrical machineries: nominal operation characteristics	60034-1	EN 60034-1	CEI EN 60034-1	4999-1 4999-69	51 200 51 111	DIN EN 60034-1	UNE EN 60034-1
Methods used for losses and yield calculation of the rotary electric machineries	60034-2	HD-53-2	CEI EN 60034-2	4999-34	51 111	DIN EN 60034-2	UNE EN 60034-2
Protection degree	60034-5	EN 60034-5	CEI EN 60034-5	4999-20	EN 60034-5	DIN EN 60034-5	20111-5
Cooling systems	60034-6	EN 60034-6	CEI EN 60034-6	4999-21		DIN EN 60034-6	EN 60034-6
Definitions of the constructive design and installation type	60034-7	EN 60034-7	CEI EN 60034-7	4999-22	51 117	DIN EN 60034-7	EN 60034-7
Marking of the terminals and rotation sensors of the rotary electric machineries	60034-8	HD 53-8 S4	CEI EN 60034-8	4999-3	51 118	DIN EN 60034-8	20113-8-96
Maximum noise level limits	60034-9	EN 60034-9	CEI EN 60034-9	4999-51	51 119	DIN EN 60034-9	EN 60034-9
50 Hz up to 600V squirrel-cage motors start up features	60034-12	EN 60034-12	CEI EN 60034-12	4999-112		DIN EN 60034-12	UNE EN 60034-12
Adjustment of the mechanical vibration intensity	60034-14	EN 60034-14	CEI EN 60034-14	4999-50	51 111	DIN EN 60034-14	EN 60034-14
Efficiency class (IE codes) for single-speed motors	60034-30		CEI EN 60034-30				
Definitions of the fastening dimensions and power values for IM B3 motors	60072	HD 231	UNEL 13113	4999-10	51 104 51 105 51 110	DIN 42673-1	UNE EN 50347
Definitions of the fastening dimensions and power values for IM B5 motors	60072	HD 231	UNEL 13117	4999-10	51 104 51 105 51 110	DIN 42677-1	
Definitions of the fastening dimensions and power values for IM B14 motors	60072	HD 231	UNEL 13118	4999-10	51 104 51 105 51 110	DIN 42677-1	UNE EN 50347
Dimensions of the shaft ends protrusions	60072	HD 231	UNEL 13502	4999-10	51 111	DIN 748-3	

**DECLARATION OF CONFORMITY**

WAM® motors are constructed in accordance with:

- The EN60034-1:2010 standard
- The 2014/30/EC regulations (EMC Directives);
- Low Voltage Directive 2014/35/UE (93/68/ EEC).
- For the motors compliant to the directive EN 1127-1:2011 (ATEX) refer to the related technical manual.

**4.1 Modular key**

MT	0800B	04	1	4	5	2	A	M
----	-------	----	---	---	---	---	---	---

**WAM motors identification abbreviation**

**Motor Size**  
0630A - 3550L

**Poles number**  
02 = 2  
04 = 4  
06 = 6  
48 = 4/8

**Voltage and Frequency**  
1 = 220-240 / 380-420 V 50 Hz; 440-480 V 60 Hz for Gr. ≤ 132  
2 = 380-420 / 660-725 V 50 Hz; 440-480 V 60 Hz for Gr. ≥ 160  
6 = 210-230 / 360-400 V 60 Hz for Gr. ≤ 132  
8 = 360-400 / 630-690 V 60 Hz for Gr. ≥ 160  
A = 380-420 V 50 Hz; 440-480 V 60 Hz (solo 4/8 poles)

**Protection class**  
4 = IP55

**Motor construction**  
3 = B3  
4 = B14  
5 = B5

**Efficiency class**  
1 = IE1 S3  
2 = IE2  
3 = IE3

**Casing material**  
“-” = Cast iron casing  
A = Aluminium casing

“-” = Standard power  
M = Increased power

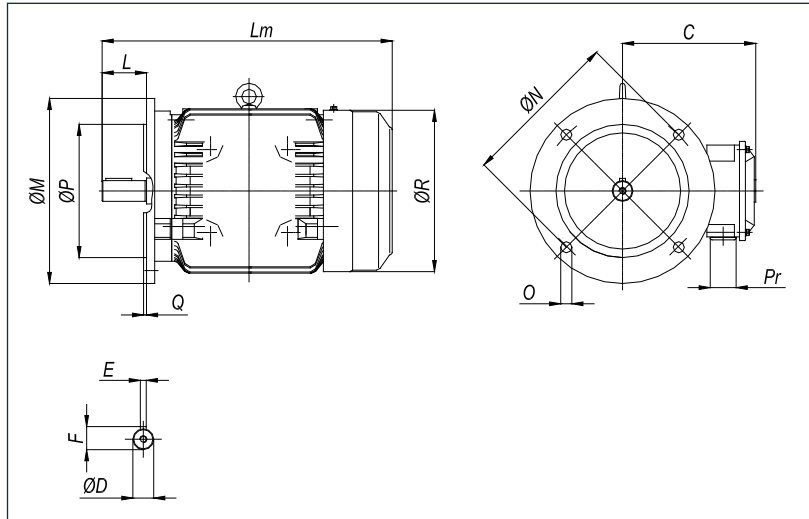

**5.1 Overall dimensions of IE1 Efficiency class WAM electric motors**
**5.1.1 B5 MOTORS (IEC)**

Power 4 P. [kW]	Size motor	C	D	E	F	L	Lm*	M	N	O		P	Q	R	Pr		Values [kg]	
										Ø	n°				n°	[mm]	AL	G
0.12	63A	70	11	4	12.5	23	225	140	115	10	4	95	3	130	1	M20 x 1,5	3.5	6
0.18	63B	70	11	4	12.5	23	225	140	115	10	4	95	3	130	1	M20 x 1,5	5.4	6
0.25	71A	80	14	5	16	30	250	160	130	10	4	110	3.5	145	1	M20 x 1,5	6	10
0.37	71B	80	14	5	16	30	250	160	130	10	4	110	3.5	145	1	M20 x 1,5	6	10
0.55	80A	150	19	6	21.5	40	285	200	165	12	4	130	3.5	160	1	M20 x 1,5	9.4	16
0.75	80B	150	19	6	21.5	40	285	200	165	12	4	130	3.5	160	1	M20 x 1,5	9.4	16
1.1	90S	155	24	8	27	50	310	200	165	12	4	130	3.5	175	1	M25 x 1,5	13	22
1.5	90L	155	24	8	27	50	335	200	165	12	4	130	3.5	175	1	M25 x 1,5	15.6	27
2.2	100LR	180	28	8	31	60	380	250	215	15	4	180	4	215	2	M25 x 1,5	21.5	37
3.0	100LH	180	28	8	31	60	380	250	215	15	4	180	4	215	2	M25 x 1,5	33	37
4.0	112M	190	28	8	31	60	400	250	215	15	4	180	4	240	2	M25 x 1,5	29.4	47
5.5	132S	210	38	10	41	80	475	300	265	15	4	230	4	275	2	M25 x 1,5	43.9	68
7.5	132M	210	38	10	41	80	515	300	265	15	4	230	4	275	2	M25 x 1,5	/	78
9.2	132ML	210	38	10	41	80	515	300	265	15	4	230	4	275	2	M25 x 1,5	/	85
11.0	160M	255	42	12	45	110	600	350	300	19	4	250	5	325	2	M32 x 1,5	/	120
15.0	160L	255	42	12	45	110	645	350	300	19	4	250	5	325	2	M32 x 1,5	/	147
18.5	180M	285	48	14	51.5	110	670	350	300	19	4	250	5	360	2	M32 x 1,5	/	173
22.0	180L	285	48	14	51.5	110	710	350	300	19	4	250	5	360	2	M32 x 1,5	/	197
30.0	200L	310	55	16	59	110	775	400	350	19	4	300	5	400	2	M50 x 1,5	/	255
37.0	225S	345	60	18	64	140	820	450	400	19	8	350	5	450	2	M50 x 1,5	/	284
45.0	225M	-	-	-	-	-	-	-	-	-	-	-	-	-	-	-	-	-
55.0	250M	-	-	-	-	-	-	-	-	-	-	-	-	-	-	-	-	-
75.0	280S	-	-	-	-	-	-	-	-	-	-	-	-	-	-	-	-	-
90.0	280M	-	-	-	-	-	-	-	-	-	-	-	-	-	-	-	-	-

dimensions in mm

**AL** = Aluminium

**G** = Cast iron

\* = ±50 mm

The weight refers to 4-pole motors

Tolerance		
D ISO j6 (up to D=28mm)	E ISO h9	P ISO j6 (up to the size 180)
D ISO k6 (from D=38mm to D=48mm)		P ISO js6 (from size 225 to size 250)
D ISO m6 (from D=55mm)		P ISO j6 (from size 280 to size 315)

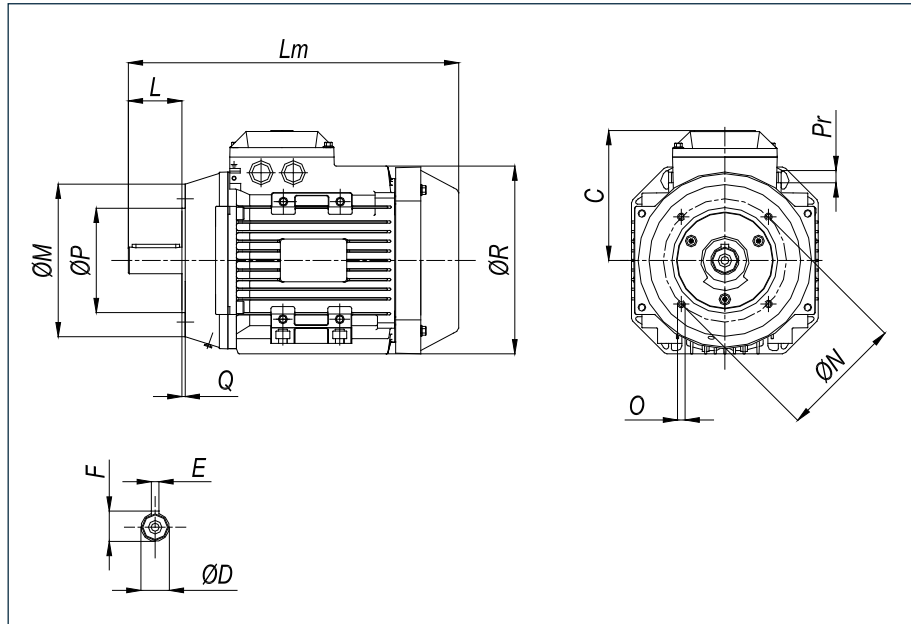
**5.1.2 B14 MOTORS (IEC)**

Power 4 P. [kW]	Size motor	C	D	E	F	L	Lm*	M	N	O		P	Q	R	Pr		Values [kg]	
										Ø	n°				n°	[mm]	AL	G
0.12	-	-	-	-	-	-	-	-	-	-	-	-	-	-	-	-	-	-
0.18	-	-	-	-	-	-	-	-	-	-	-	-	-	-	-	-	-	-
0.25	71A	110	14	5	16	30	247	105	85	M6	4	70	2.5	138	1	M20 x 1,5	6.2	10
0.37	71B	110	14	5	16	30	247	105	85	M6	4	70	2.5	138	1	M20x 1.5	6.4	10
0.55	-	-	-	-	-	-	-	-	-	-	-	-	-	-	-	-	-	-
0.75	-	-	-	-	-	-	-	-	-	-	-	-	-	-	-	-	-	-
1.1	-	-	-	-	-	-	-	-	-	-	-	-	-	-	-	-	-	-
1.5	-	-	-	-	-	-	-	-	-	-	-	-	-	-	-	-	-	-
2.2	-	-	-	-	-	-	-	-	-	-	-	-	-	-	-	-	-	-
3.0	-	-	-	-	-	-	-	-	-	-	-	-	-	-	-	-	-	-
4.0	-	-	-	-	-	-	-	-	-	-	-	-	-	-	-	-	-	-

dimensions in mm

**AL** = Aluminium

**G** = Cast iron

\* = ±50 mm

The weight refers to 4-pole motors

Tolerance		
D ISO j6 (up to D=28mm)	E ISO h9	P ISO j6 (up to the size 180)
D ISO k6 (from D=38mm to D=48mm)		P ISO js6 (from size 225 to size 250)
D ISO m6 (from D=55mm)		P ISO j6 (from size 280 to size 315)

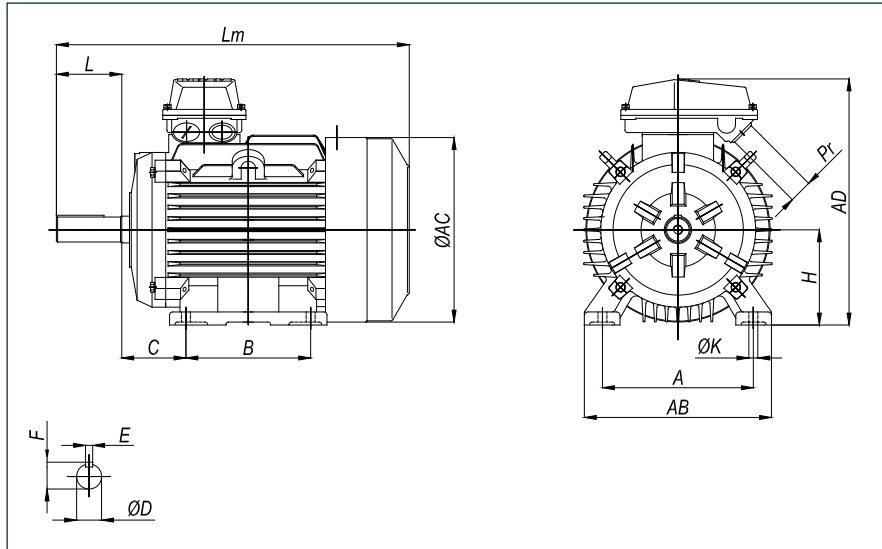
**5.1.3 B3 MOTORS (IEC)**

Power 4 P. [kW]	Size motor	AB	AC	AD	Lm*	A	B	C	D	E	F	L	H	K	Pr		Values [kg]	
															n°	[mm]	AL	G
5.5	132S	-	-	-	-	-	-	-	-	-	-	-	-	-	-	-	-	-
7.5	132M	-	-	-	-	-	-	-	-	-	-	-	-	-	-	-	-	-
9.2	132ML	-	-	-	-	-	-	-	-	-	-	-	-	-	-	-	-	-
11.0	160M	330	325	420	600	254	210	108	42	12	45	110	160	15	2	M32 x 1.5	/	120
15.0	160L	330	325	420	645	254	254	108	42	12	45	110	160	15	2	M32 x 1.5	/	143
18.5	180M	355	360	455	670	279	241	121	48	14	51.5	110	180	15	2	M32 x 1.5	/	173
22.0	180L	355	360	455	710	279	279	121	48	14	51.5	110	180	15	2	M32 x 1.5	/	197
30.0	200L	395	420	505	770	318	305	133	55	16	59	110	200	19	2	M50 x 1.5	/	260
37.0	225S	435	450	555	820	356	286	149	60	18	64	140	225	19	2	M50 x 1.5	/	284
45.0	225M	435	450	555	845	356	311	149	60	18	64	140	225	19	2	M50 x 1.5	/	320
55.0	250M	490	495	615	930	406	349	168	65	18	69	140	250	24	2	M50 x 1.5	/	300
75.0	280S	550	555	680	1000	457	368	190	75	20	79.5	140	280	24	2	M63 x 1.5	/	560
90.0	280M	550	555	680	1050	457	419	190	75	20	79.5	140	280	24	2	M63 x 1.5	/	660
110.0	315S	640	645	845	1190	508	406	216	80	22	85	170	315	28	2	M63 x 1.5	/	910
132.0	315M	640	645	845	1240	508	457	216	80	22	85	170	315	28	2	M63 x 1.5	/	1020
160.0	315L	640	645	845	1340	508	508	216	80	22	85	170	315	28	2	M63 x 1.5	/	1170
200.0	315L2	640	645	845	1340	508	508	216	80	22	85	170	315	28	2	M63 x 1.5	/	1270

dimensions in mm

**AL** = Aluminium

**G** = Cast iron

\* = ±50 mm

 = not available

The weight refers to 4-Pole motors

Tolerance	
<b>A, B ISO js14</b>	<b>H</b> +0 -0.5 <b>H</b> +0 -1.0 (from size 280 up to size 315)
<b>C</b> +0 -2	
<b>D ISO j6</b> (up to D=28mm)	
<b>D ISO k6</b> (from D=38mm to D=48mm)	
<b>D ISO m6</b> (from D=55mm)	
<b>E ISO h9</b>	

## 5.2 Electro-mechanical features of IE1 Efficiency class WAM electric motors

### 5.2.1 2-Pole standard motors with wound rotors for 50Hz and use at 50Hz

Frame Size	Rated power [kW]	Freq. [Hz]	Voltage [V]	Current 400V [A]	Poles	Speed [rpm]	Cos. $\phi$	Cn rated torque [Nm]	Cs/Cn Locked rotor torque/ rated torque	Is/In Locked rotor current/ rated current	Cmax/Cn Break-down torque/ rated torque
63A	-	-	-	-	-	-	-	-	-	-	-
63B	-	-	-	-	-	-	-	-	-	-	-
71A	0.55	50	230/400	1.4	2	2800	0.82	1.9	2.2	6.1	2.3
71B	-	-	-	-	-	-	-	-	-	-	-
80A	0.75	50	230/400	1.8	2	2825	0.83	2.5	2.2	6.1	2.3
80B	1.1	50	230/400	2.6	2	2825	0.84	3.7	2.2	7.0	2.3
90S	1.5	50	230/400	3.4	2	2840	0.83	5.0	2.2	7.0	2.3
90L	2.2	50	230/400	4.9	2	2840	0.85	7.4	2.2	7.0	2.3
100LR	3.0	50	230/400	6.3	2	2880	0.87	9.9	2.2	7.5	2.3
100LH	-	-	-	-	-	-	-	-	-	-	-
112M	4.0	50	230/400	8.1	2	2890	0.88	13.2	2.2	7.5	2.3
132S1	5.5	50	230/400	11.0	2	2900	0.88	18.1	2.2	7.5	2.3
132S2	7.5	50	230/400	14.0	2	2900	0.88	24.7	2.2	7.5	2.3
132M	9.2	50	230/400	18.0	2	2870	0.88	30.6	2.0	7.0	2.1
132ML	-	-	-	-	-	-	-	-	-	-	-
160M	11.0	50	400/690	21.0	2	2930	0.89	35.9	2.2	7.5	2.3
160L	-	-	-	-	-	-	-	-	-	-	-
180M	-	-	-	-	-	-	-	-	-	-	-
180L	-	-	-	-	-	-	-	-	-	-	-
200L	-	-	-	-	-	-	-	-	-	-	-

**NOTES:** - The values given in the table refer to continuous duty S1

- The values given are typical but not guaranteed

- Available motors for S3/75% duty

**5.0 IE1 MOTORS**
**5.2.2 4-Pole standard motors with wound rotors for 50Hz and use at 50Hz**

Frame Size	Rated power [kW]	Freq. [Hz]	Voltage [V]	Current 400V [A]	Poles	Speed [rpm]	Cos. $\varphi$	Cn rated torque [Nm]	Cs/Cn Locked rotor torque/ rated torque	Is/In Locked rotor current/ rated current	Cmax/Cn Break-down torque/ rated torque
63A	0.12	50	230/400	0.4	4	1400	0.72	0.8	2.1	4.4	2.2
63B	0.18	50	230/400	0.6	4	1400	0.73	1.2	2.1	4.4	2.2
71A	0.25	50	230/400	0.8	4	1400	0.74	1.7	2.1	5.2	2.2
71B	0.37	50	230/400	1.1	4	1400	0.75	2.5	2.1	5.2	2.2
80A	0.55	50	230/400	1.6	4	1390	0.75	3.8	2.4	5.2	2.3
80B	0.75	50	230/400	2.0	4	1390	0.77	5.2	2.4	6.0	2.3
90S	1.1	50	230/400	2.9	4	1400	0.77	7.5	2.3	6.0	2.3
90L	1.5	50	230/400	3.7	4	1400	0.79	10.2	2.3	6.0	2.3
100LR	2.2	50	230/400	5.2	4	1420	0.81	14.8	2.3	7.0	2.3
100LH	3.0	50	230/400	6.8	4	1420	0.82	20.2	2.3	7.0	2.3
112M	4.0	50	230/400	8.8	4	1440	0.82	26.5	2.3	7.0	2.3
132S	5.5	50	230/400	11.8	4	1440	0.83	36.5	2.3	7.0	2.3
132M	7.5	50	230/400	15.6	4	1440	0.84	49.7	2.3	7.0	2.3
132ML	9.2	50	230/400	18.0	4	1430	0.84	61.4	2.3	7.0	2.3
160M	11.0	50	400/690	22.0	4	1460	0.54	72.0	2.2	7.0	2.3
160L	15.0	50	400/690	30.0	4	1460	0.85	98.1	2.2	7.0	2.3
180M	18.5	50	400/690	36.0	4	1470	0.86	120.2	2.2	7.5	2.3
180L	22.0	50	400/690	43.0	4	1470	0.86	142.9	2.2	7.5	2.3
200L	30.0	50	400/690	58.0	4	1480	0.86	194	2.2	7.5	2.3
225S	37.0	50	400/690	70.0	4	1480	0.87	239	2.2	7.5	2.3
225M	-	-	-	-	-	-	-	-	-	-	-
250M	-	-	-	-	-	-	-	-	-	-	-
280S	-	-	-	-	-	-	-	-	-	-	-

**NOTES:** - The values given in the table refer to continuous duty S1

- The values given are typical but not guaranteed

- Available motors for S3/75% duty

■ = Consult the supplier

**5.2.3 6-Pole standard motors with wound rotors for 50Hz and use at 50Hz**

Frame Size	Rated power [kW]	Freq. [Hz]	Voltage [V]	Current 400V [A]	Poles	Speed [rpm]	Cos. $\varphi$	Cn [Nm]	Cs/Cn	Is/In	Cmax/Cn
90L	1.10	50	230/400	3.0	6	910	0.73	11.5	2.0	6.0	2.2

**NOTES:** - The values given in the table refer to continuous duty S1

- The values given are typical but not guaranteed

- Available motors for S3/75% duty

**5.2.4 Double speed motors with DAHLANDER winding for 50Hz and use at 50Hz 4/8 Poles**

Frame Size	Rated power [kW]	Freq. [Hz]	Voltage [V]	Current 400V [A]	Poles	Speed [rpm]	Cos. $\phi$	Cn rated torque [Nm]	Cs/Cn Locked rotor torque/rated torque	Is/In Locked rotor torque/rated torque	Cmax/Cn Break-down torque/rated torque
112M	1.50	50	400	4.60	8	710	0.65	20.2	1.5	5.5	1.8
	3.00	50	400	8.00	4	1430	0.65	20.0	1.5	6.5	1.8
132S	2.20	50	400	6.70	8	720	0.63	29.2	1.5	5.5	1.8
	3.30	50	400	6.80	4	1440	0.85	21.9	1.5	6.5	1.8
132M	3.00	50	400	8.85	8	720	0.63	39.8	1.5	5.5	1.8
	4.40	50	400	8.83	4	1440	0.86	29.2	1.5	6.5	1.8
160M	4.50	50	400	12.40	8	720	0.64	59.7	1.5	5.5	1.8
	6.00	50	400	12.00	4	1440	0.86	39.8	1.5	6.5	1.8
160MB	6.00	50	400	15.90	8	730	0.64	78.5	1.5	5.5	1.8
	8.50	50	400	16.20	4	1450	0.87	56	1.5	6.5	1.8
1600L	7.50	50	400	19.30	8	730	0.66	98.1	1.5	5.5	1.8
	10.00	50	400	19.10	4	1450	0.87	65.9	1.5	6.5	1.8
1800L	10.00	50	400	23.00	8	730	0.72	130.8	1.5	6.0	1.8
	15.00	50	400	27.30	4	1470	0.91	97.4	1.5	7.0	1.8

**NOTES:** - The values given in the table refer to continuous duty S1  
 - The values given are typical but not guaranteed

**5.2.5 2-Pole standard motors with woundrotors for 50Hz and use at 60Hz for the USA**

Frame Size	Rated power 50Hz [kW]	Rated power 60Hz [kW]	Freq. [Hz]	Voltage [V]	Current 460V [A]	Poles	Speed [rpm]	Cos. $\phi$	Cn [Nm]	Cs/Cn	Is/In	Cmax/Cn
71A	0.55	0.63	60	440-480	1.2	2	3420	0.83	1.8	2.2	6.0	2.2
80A	0.75	0.86	60	440-480	1.4	2	3450	0.85	2.4	2.2	7.0	2.5
80B	1.1	1.26	60	440-480	2.5	2	3420	0.85	3.5	2.2	7.0	2.2
90S	1.5	1.73	60	440-480	3.2	2	3420	0.84	4.8	2.2	7.0	2.2
90L	2.2	2.53	60	440-480	4.5	2	3420	0.88	7.1	2.2	7.0	2.2
100LR	3.0	3.45	60	440-480	6.2	2	3440	0.87	9.6	2.2	7.0	2.2
112M	4.0	4.60	60	440-480	7.9	2	3440	0.89	12.8	2.2	7.0	2.3
132S	5.5	6.33	60	440-480	9.1	2	3440	0.88	17.6	2.2	7.0	2.3
132S	7.5	8.63	60	440-480	12.2	2	3440	0.89	24.0	2.2	7.0	2.3
132M	9.2	10.58	60	440-480	15.1	2	3440	0.88	29.4	2.0	7.0	2.1
160M	11.0	12.65	60	440-480	19.7	2	3440	0.85	35.1	2.0	7.0	2.2
-	-	-	-	-	-	-	-	-	-	-	-	-
-	-	-	-	-	-	-	-	-	-	-	-	-

**NOTES:** - The values given in the table refer to continuous duty S1  
 - The values given are typical but not guaranteed  
 - Available motors for S3/75% duty

**5.2.6 4-Pole standard motors with wound rotors for 50Hz and use at 60Hz for the USA**

Frame Size	Rated power 50Hz [kW]	Rated power 60Hz [kW]	Freq. [Hz]	Voltage [V]	Current 460V [A]	Poles	Speed [rpm]	Cos. $\varphi$	Cn [Nm]	Cs/Cn	Is/In	Cmax/Cn
63A	0.12	0.14	60	440-480	0.41	4	1630	0.67	0.8	2.2	6.0	2.2
63B	0.18	0.20	60	440-480	0.59	4	1630	0.69	1.2	2.2	6.0	2.2
71A	0.25	0.29	60	440-480	0.82	4	1630	0.69	1.7	2.2	6.0	2.2
71B	0.37	0.43	60	440-480	1.0	4	1630	0.71	2.5	2.2	6.0	2.2
80A	0.55	0.63	60	440-480	1.33	4	1710	0.78	3.5	2.2	6.0	2.2
80B	0.75	0.86	60	440-480	1.95	4	1690	0.79	4.9	2.2	6.0	2.2
90S	1.1	1.26	60	440-480	2.7	4	1690	0.79	7.1	2.2	6.5	2.2
90L	1.5	1.73	60	440-480	3.6	4	1700	0.79	9.7	2.2	6.5	2.2
100LR	2.2	2.5	60	440-480	5.2	4	1716	0.80	14.1	2.2	7.0	2.3
112LM	3.0	3.45	60	440-480	6.5	4	1716	0.82	19.2	2.2	7.0	2.3
112M	4.0	4.6	60	440-480	9.0	4	1716	0.83	25.6	2.2	7.0	2.3
132S	5.5	6.3	60	440-480	10.9	4	1716	0.84	35.2	2.2	7.0	2.3
132M	7.5	8.6	60	440-480	14.9	4	1716	0.85	48.0	2.2	7.0	2.3
132L	9.2	10.5	60	440-480	17.9	4	1716	0.84	58.9	2.2	7.0	2.3
160M	11.0	12.6	60	440-480	21.8	4	1750	0.84	69.0	2.2	7.0	2.2
160L	15.0	17.2	60	440-480	28.8	4	1750	0.87	94.1	2.2	7.0	2.2
180M	18.5	21.3	60	440-480	33.9	4	1764	0.89	115.2	2.0	7.0	2.2
180L	22.0	25	60	440-480	39.8	4	1764	0.86	137.0	2.0	7.0	2.2
200L	30.0	34.5	60	440-480	56.5	4	1764	0.87	186.8	2.0	7.0	2.2
225S	37.0	42.5	60	440-480	70.0	4	1776	0.90	228.8	1.9	7.0	2.2

**NOTES:** - The values given in the table refer to continuous duty S1

- The values given are typical but not guaranteed

- Available motors for S3/75% duty

■ = Consult the supplier

**5.2.7 4-Pole standard motors with wound rotors for 50Hz and use at 60Hz for the USA**

Frame Size	Rated power 50Hz [kW]	Rated power 60Hz [kW]	Freq. [Hz]	Voltage [V]	Current 460V [A]	Poles	Speed [rpm]	Cos. $\varphi$	Cn [Nm]	Cs/Cn	Is/In	Cmax/Cn
90L	1.10	1.26	60	440-480	3.0	6	1090	0.73	11.0	2.0	6.0	2.2

**NOTES:** - The values given in the table refer to continuous duty S1

- The values given are typical but not guaranteed

- Available motors for S3/75% duty

**5.0 IE1 MOTORS**
**5.2.8 4/8 Poles double-speed motors with DAHLANDER winding for 50Hz and use at 60Hz for the USA**

Frame Size	Rated power 50Hz [kW]	Rated power 60Hz [kW]	Freq. [Hz]	Voltage [V]	Current 460V [A]	Poles	Speed [rpm]	Cos. $\phi$	Cn [Nm]	Cs/Cn	Is/In	Cmax/Cn
112M	1.50	1.80	60	440-480	4.60	8	852	0.65	20.2	1.5	5.5	1.8
	3.00	3.60	60	440-480	8.00	4	1716	0.65	20.0	1.5	6.5	1.8
132S	2.20	2.60	60	440-480	6.70	8	964	0.63	28.7	1.5	5.5	1.8
	3.30	4.00	60	440-480	6.80	4	1728	0.85	22.1	1.5	6.5	1.8
132M	3.00	3.60	60	440-480	8.90	8	864	0.63	39.8	1.5	5.5	1.8
	4.40	5.30	60	440-480	8.80	4	1728	0.86	29.3	1.5	6.5	1.8
160M	4.50	5.40	60	440-480	12.40	8	876	0.64	58.9	1.5	5.5	1.8
	6.00	7.20	60	440-480	12.00	4	1740	0.86	39.5	1.5	6.5	1.8
160MB	6.00	7.20	60	440-480	15.90	8	876	0.64	75.5	1.5	5.5	1.8
	8.50	10.20	60	440-480	16.20	4	1740	0.87	56.0	1.5	6.5	1.8
1600L	7.50	9.00	60	440-480	19.30	8	876	0.66	98.1	1.5	5.5	1.8
	10.00	12.00	60	440-480	19.10	4	1740	0.87	65.9	1.5	6.5	1.8
1800L	10.00	12.00	60	440-480	23.00	8	876	0.72	130.8	1.5	6.0	1.8
	15.00	18.00	60	440-480	27.30	4	1764	0.91	97.4	1.5	7.0	1.8

**NOTES:** - The values given in the table refer to continuous duty S1  
 - The values given are typical but not guaranteed

**5.2.9 2-Pole standard motors with wound rotors for 60Hz and use at 60Hz for the South America**

Frame Size	Rated power [kW]	Freq. [Hz]	Voltage [V]	Current 380V [A]	Poles	Speed [rpm]	Cos. $\phi$	Cn rated torque [Nm]	Cs/Cn Locked rotor torque/rated torque	Is/In Locked rotor current/rated current	Cmax/Cn Break-down torque/rated torque
63A	-	-	-	-	-	-	-	-	-	-	-
63B	-	-	-	-	-	-	-	-	-	-	-
71A	0.55	60	220/380	1.3	2	3440	0.83	1.5	2.1	6.0	2.1
71B	-	-	-	-	-	-	-	-	-	-	-
80A	0.75	60	220/380	1.8	2	3440	0.84	2.1	2.0	7.0	2.0
80B	1.1	60	220/380	2.5	2	3440	0.84	3.1	2.0	7.0	2.0
90S	1.5	60	220/380	3.3	2	3470	0.83	4.1	2.0	7.0	2.0
90L	2.2	60	220/380	4.6	2	3470	0.87	6.1	2.0	7.0	2.0
100LR	3.0	60	220/380	5.8	2	3450	0.87	8.3	2.0	7.0	2.1
100LH	-	-	-	-	-	-	-	-	-	-	-
112M	4.0	60	220/380	7.4	2	3450	0.89	11.1	2.0	7.0	2.1
132S	5.50	60	220/380	11.1	2	3480	0.88	15.1	2	8	2.1
132M	7.50	60	220/380	14.9	2	3444	0.88	20.8	2	7.8	2.1
132ML	-	-	-	-	-	-	-	-	-	-	-
160M	11.00	60	400/690	21.2	2	3516	0.89	29.9	2	7.9	2.1
160L	-	-	-	-	-	-	-	-	-	-	-
180M	-	-	-	-	-	-	-	-	-	-	-
180L	-	-	-	-	-	-	-	-	-	-	-

**NOTES:** - The values given in the table refer to continuous duty S1  
 - The values given are typical but not guaranteed  
 - Available motors for S3/75% duty



**5.2.10 4-Pole standard motors with wound rotors for 60Hz and use at 60Hz for the South America**

Frame Size	Rated power [kW]	Freq. [Hz]	Voltage [V]	Current 380V [A]	Poles	Speed [rpm]	Cos. $\varphi$	Cn rated torque [Nm]	Cs/Cn Locked rotor torque/ rated torque	Is/In Locked rotor current/ rated current	Cmax/Cn Break-down torque/ rated torque
63	0.25	60	220/380	0.80	4	1640	0.67	1.5	2.2	6.0	2.2
71A	0.25	60	220/380	0.80	4	1630	0.68	1.5	2.2	6.0	2.2
71B	0.37	60	220/380	1.2	4	1630	0.69	2.2	2.2	6.0	2.2
80A	-	-	-	-	-	-	-	-	-	-	-
80B	0.75	60	220/380	2.0	4	1680	0.78	4.3	2.1	6.0	2.1
90S	1.10	60	220/380	2.6	4	1710	0.78	6.1	2.1	6.5	2.1
90L	1.50	60	220/380	3.7	4	1710	0.79	8.4	2.1	6.5	2.1
100LR	2.20	60	220/380	5.0	4	1720	0.81	12.2	2.0	7.0	2.1
100LH	3.30	60	220/380	6.8	4	1720	0.82	18.3	2.0	7.0	2.1
112M	4.00	60	220/380	8.2	4	1720	0.83	22.2	2.0	7.0	2.1
132S	5.50	60	220/380	11.2	4	1730	0.82	30.4	2.0	7.0	2.1
132M	7.50	60	220/380	14.9	4	1710	0.85	41.9	2.0	7.0	2.1
132ML	9.20	60	220/380	18.0	4	1720	0.84	51.1	2.0	7.0	2.1
160M	11.00	60	400/690	22.0	4	1750	0.85	60.0	2.2	7.0	2.2
160L	15.00	60	400/690	29.0	4	1752	0.85	81.8	2.2	7.0	2.2
180M	18.5	60	400/690	36.3	4	1764	0.86	100.2	2	7.7	2.1
180L	22.0	60	400/690	42.9	4	1764	0.86	119.1	2	7.8	2.1
200L	-	-	-	-	-	-	-	-	-	-	-
225S	-	-	-	-	-	-	-	-	-	-	-

- NOTES:** - The values given in the table refer to continuous duty S1  
 - The values given are typical but not guaranteed  
 - Available motors for S3/75% duty

**5.2.11 6-Pole standard motors with wound rotors for 60Hz and use at 60Hz for the South America**

Frame Size	Rated power [kW]	Freq. [Hz]	Voltage [V]	Current 380V [A]	Poles	Speed [rpm]	Cos. $\varphi$	Cn rated torque [Nm]	Cs/Cn Locked rotor torque/ rated torque	Is/In Locked rotor current/ rated current	Cmax/Cn Break-down torque/ rated torque
90L	1.1	60	220/380	3.2	6	1092	0.73	9.6	1.9	5.9	1.9

- NOTES:** - The values given in the table refer to continuous duty S1  
 - The values given are typical but not guaranteed  
 - Available motors for S3/75% duty

**5.2.12 2-Pole motors with wound rotors for 60Hz with NEMA flange**

Frame Size	Rated power [HP]	Speed [rpm]	Voltage [V]	Current 460V [A]	Cos. $\varphi$	Cn rated torque [Nm]	Cs/Cn Locked rotor torque/rated torque	Is/In Locked rotor current/rated current	Cmax/Cn Break-down torque/rated torque
<b>56C</b>	1	3380	230-460	1.9	0.82	2.1	2.2	5	2.5
<b>143C</b>	1.5	3480	230-460	1.9	0.84	3.0	2.2	5.3	2.5
<b>145C</b>	2	3480	230-460	2.5	0.86	4.0	2.2	5.9	2.4
<b>182C</b>	3	3410	230-460	4.2	0.83	6.2	2.2	5.5	2.3
<b>184C</b>	5	3490	230-460	6.3	0.85	10.1	2.2	8.50	2.15
<b>213C</b>	7.5	3480	230-460	9.3	0.87	15.1	2.2	7.00	2
<b>215C</b>	10	3480	230-460	12.7	0.86	20.2	2	7.70	2
<b>254C</b>	15	3490	230-460	18.7	0.86	30.2	2	7.60	2
<b>256C</b>	20	3500	230-460	24.9	0.87	40.1	2	7.50	2
<b>284C</b>	25	3490	230-460	31.1	0.87	50.3	2	8.30	2
<b>286C</b>	30	3540	230-460	35.0	0.88	59.5	2	7.60	2
<b>324C</b>	40	3530	230-460	47	0.9	79.6	2	9	2
<b>Nota</b>	The values in the Table refer to continuous service S1.								

- NOTES:** - The values given in the table refer to continuous duty S1  
 - The values given are typical but not guaranteed  
 - Available motors for S3/75% duty

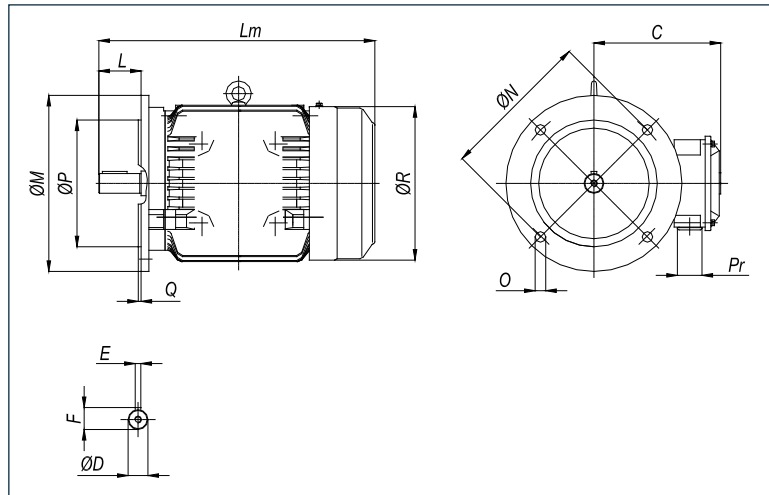
**6.1 Overall dimensions of IE2 Efficiency class WAM electric motors**
**6.1.1 B5 MOTORS (IEC)**

Power 4 P. [kW]	Size motor	C	D	E	F	L	Lm*	M	N	O		P	Q	R	Pr		Values [kg]
										Ø	n°				n°	Ø	
0,75	80B	145	19	6	21,5	40	305	200	165	12	4	130	3,5	165	1	M25 x 1,5	19
	80B (AL)																13
1,1	90S	160	24	8	27	50	355	200	165	12	4	130	3,5	190	1	M25 x 1,5	23
	90S (AL)	320					195										15
1,5	90L	160	24	8	27	50	385	200	165	12	4	130	3,5	190	1	M25 x 1,5	27
	90L (AL)	345					195										18
2,2	100LR	180	28	8	31	60	410	250	215	15	4	180	4	220	1	M25 x 1,5	36
	100LR (AL)						400										25
3	100LH	180	28	8	31	60	410	250	215	15	4	180	4	220	1	M25 x 1,5	40
	100LH (AL)						400										29
4	112M	190	28	8	31	60	470	250	215	15	4	180	4	225	2	M32 x 1,5	50
	112M (AL)	200					410							240			35
5,5	132S	210	38	10	41	80	480	300	265	15	4	230	4	275	2	M32 x 1,5	76
	132S (AL)						470										57
7,5	132 M	210	38	10	41	80	520	300	265	15	4	230	4	275	2	M32 x 1,5	81
9,2	132 ML	210	38	10	41	80	530	300	265	15	4	230	4	275	2	M32 x 1,5	88
11	160 M	255	42	12	45	110	670	350	300	19	4	250	4	335	2	M32 x 1,5	130
15	160 L	255	42	12	45	110	700	350	300	19	4	250	4	335	2	M32 x 1,5	145
18,5	180 M	280	48	14	51,5	110	810	350	300	19	4	250	4	380	2	M32 x 1,5	180
22	180 L	280	48	14	51,5	110	750	350	300	19	4	250	4	380	2	M32 x 1,5	200
30	200 L	310	55	16	59	110	820	400	350	19	4	300	5	420	2	M50 x 1,5	270
37	225 S	335	60	18	64	140	820	450	400	19	8	350	5	470	2	M50 x 1,5	300
45	225M	-	-	-	-	-	-	-	-	-	-	-	-	-	-	-	-
55	250M	-	-	-	-	-	-	-	-	-	-	-	-	-	-	-	-
75	280S	-	-	-	-	-	-	-	-	-	-	-	-	-	-	-	-

dimensions in mm

**AL** = Aluminium

**G** = Cast iron

\* = ±50 mm

The weight refers to 4-pole motors

Tolerance		
<b>D ISO j6</b> (up to D=28mm)	<b>E ISO h9</b>	<b>P ISO j6</b> (up to the size 180)
<b>D ISO k6</b> (from D=38mm to D=48mm)		<b>P ISO js6</b> (from size 225 to size 250)
<b>D ISO m6</b> (from D=55mm)		<b>P ISO j6</b> (from size 280 to size 315)

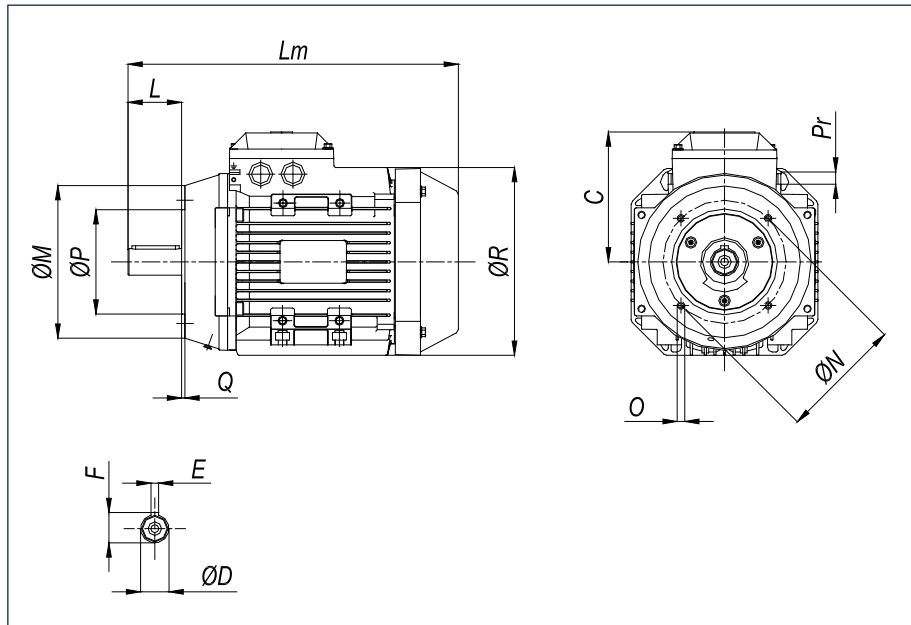
**6.1.2 B14 MOTORS (IEC)**

Power 4 P. [kW]	Size motor	C	D	E	F	L	Lm*	M	N	O		P	Q	R	Pr		Values [kg]
										Ø	n°				n°	Ø	
0.25	71A	-	-	-	-	-	-	-	-	-	-	-	-	-	-	-	-
	71A (AL)	-	-	-	-	-	-	-	-	-	-	-	-	-	-	-	-
0.37	71B	-	-	-	-	-	-	-	-	-	-	-	-	-	-	-	-
	71B (AL)	-	-	-	-	-	-	-	-	-	-	-	-	-	-	-	-
0.55	80A	-	-	-	-	-	-	-	-	-	-	-	-	-	-	-	-
	80A (AL)	-	-	-	-	-	-	-	-	-	-	-	-	-	-	-	-
0.75	80B	145	19	6	21.5	40	305	120	100	M6	4	80	3	165	1	M25 x 1,5	18.5
	80B (AL)	145	19	6	21.5	40	305	120	100	M6	4	80	3	165	1	M25 x 1,5	12
1.1	90S	160	24	8	27	50	355	140	115	M8	4	95	3	190	1	M25 x 1,5	22
	90S (AL)	165	24	8	27	50	320	140	115	M8	4	95	3	195	1	M25 x 1,5	15
1.5	90L	160	24	8	27	50	385	140	115	M8	4	95	3	190	1	M25 x 1,5	26
	90L (AL)	165	24	8	27	50	345	140	115	M8	4	95	3	195	1	M25 x 1,5	17.5
2.2	100LR	180	28	8	31	60	410	160	130	M8	4	110	3.5	220	1	M25 x 1,5	34.5
	100LR (AL)	180	28	8	31	60	400	160	130	M8	4	110	3.5	220	1	M25 x 1,5	24
3	100LH	180	28	8	31	60	410	160	130	M8	4	110	3.5	220	1	M25 x 1,5	38.5
	100LH (AL)	180	28	8	31	60	400	160	130	M8	4	110	3.5	220	1	M25 x 1,5	28
4	112M	190	28	8	31	60	470	160	130	M8	4	110	3.5	225	2	M32 x 1.5	48.5
	112M (AL)	200	28	8	31	60	410	160	130	M8	4	110	3.5	240	2	M32 x 1.5	34
5.5	132S	210	38	10	41	80	480	200	165	M10	4	130	4	275	2	M32 x 1.5	74
	132S (AL)	210	38	10	41	80	470	200	165	M10	4	130	4	275	2	M32 x 1.5	56

dimensions in mm

**AL** = Aluminium

**G** = Cast iron

\* = ±50 mm

 = not available

The weight refers to 4-pole motors

Tolerance		
D ISO j6 (up to D=28mm)	E ISO h9	P ISO j6 (up to the size 180)
D ISO k6 (from D=38mm to D=48mm)		P ISO js6 (from size 225 to size 250)
D ISO m6 (from D=55mm)		P ISO j6 (from size 280 to size 315)

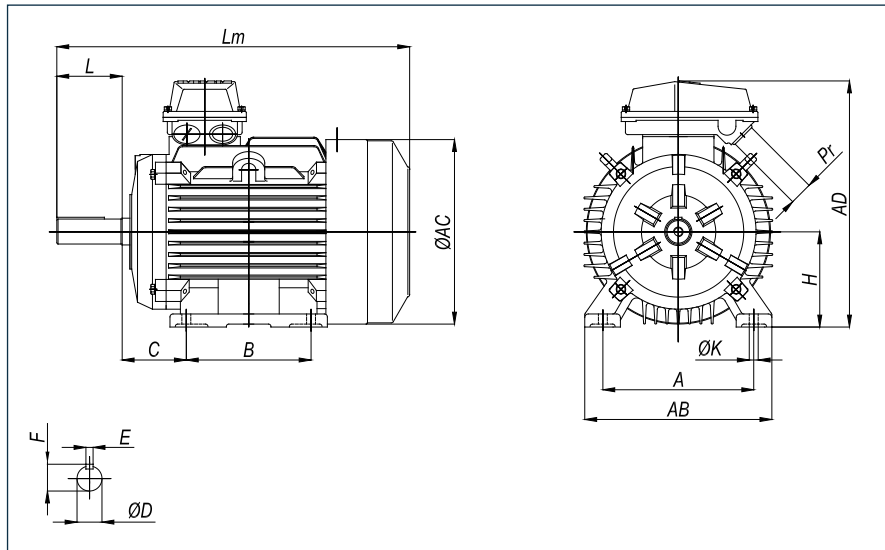
**6.1.3 B3 MOTORS (IEC)**

Power 4 P. [kW]	Size motor	A	B	C	D	E	F	H	K	L	Lm*	AB	AC	AD	Pr		Values [kg]
															n°	Ø	
5.5	132S	-	-	-	-	-	-	-	-	-	-	-	-	-	-	-	-
7.5	132M	-	-	-	-	-	-	-	-	-	-	-	-	-	-	-	-
9.2	132L	-	-	-	-	-	-	-	-	-	-	-	-	-	-	-	-
11	160 M	254	210	108	42	12	45	160	15	110	670	320	335	420	2	M32 x 1.5	130
15	160 L	254	254	108	42	12	45	160	15	110	700	320	335	420	2	M32 x 1.5	146
18.5	180 M	279	241	121	48	14	51.5	180	15	110	710	355	380	460	2	M32 x 1.5	180
22	180 L	279	279	121	48	14	51.5	180	15	110	750	355	380	460	2	M32 x 1.5	200
30	200 L	318	305	133	55	16	59	200	19	110	820	395	420	510	2	M50 x 1.5	275
37	225 S	356	286	149	60	18	64	225	19	140	820	435	470	560	2	M50 x 1.5	300
45	225M	356	311	149	60	18	64	225	19	140	845	435	470	560	2	M50 x 1.5	320
55	250 M	406	349	168	65	18	69	250	24	140	915	490	510	615	2	M50 x 1.5	410
75	280S	457	368	190	75	20	79.5	280	24	140	985	550	580	680	2	M50 x 1.5	600
90	280M	457	419	190	75	20	79.5	280	24	140	1035	550	580	680	2	M50 x 1.5	640
110	315S	508	406	216	80	22	85	315	28	170	1290	635	645	845	2	M50 x 1.5	1015
132	315M	508	457	216	80	22	85	315	28	170	1320	635	645	845	2	M50 x 1.5	1110
160	315L	508	508	216	80	22	85	315	28	170	1320	635	645	845	2	M50 x 1.5	1170
200	315L2	508	508	216	80	22	85	315	28	170	1320	635	645	845	2	M50 x 1.5	1280

\* = ±50 mm

dimensions in mm

■ = not available

The weight refers to 4-pole motors

Tolerance	
A, B ISO js14	H +0 -0.5
C +0 -2	H +0 -1.0 (from size 280 up to size 315)
D ISO j6 (up to D=28mm)	
D ISO k6 (from D=38mm to D=48mm)	
D ISO m6 (from D=55mm)	
E ISO h9	

## 6.2 Electro-mechanical features of IE2 Efficiency class WAM electric motors

### 6.2.1 2-Pole standard motors with wound rotors for 50Hz and use at 50Hz

Frame Size IEC	Rated power [kW]	Speed [rpm]	Voltage [V]	Current 380V [A]	Efficiency			Cos. $\phi$	Cn rated torque [Nm]	Cs/Cn Locked rotor torque/ rated torque	Is/In Locked rotor current/rated current	Cmax/Cn Break-down torque/rated torque
					100%	75%	50%					
80A	0.75	2865	400	1.69	77.4	79.0	76.6	0.83	2.50	2.3	6.80	2.30
80B	1.1	2885	400	2.40	79.6	80.2	77.2	0.83	3.64	2.3	7.30	2.30
90S	1.5	2885	400	3.17	81.3	80.6	79.8	0.84	4.95	2.3	7.60	2.30
90L	2.2	2895	400	4.49	83.2	83.6	83.1	0.85	7.26	2.3	7.80	2.30
100LR	-	-	-	-	-	-	-	-	-	-	-	-
100LH	3	2915	400	5.88	84.6	84.7	83.2	0.87	9.83	2.3	8.10	2.30
112M	4	2895	400	7.65	85.8	86.3	86.0	0.88	13.20	2.3	8.30	2.30
132S	5.5	2925	400	10.40	87.0	86.7	84.7	0.88	17.96	2.2	8.00	2.30
132M	7.5	2925	400	13.80	88.1	87.6	87.2	0.89	24.49	2.2	7.80	2.30
132ML	9.20	2925	400	15.00	88.8	88.5	87.4	0.89	30.00	2.2	7.80	2.30
160M	11	2930	400	20.00	89.4	89.5	87.7	0.89	35.85	2.2	7.90	2.30
160L	-	-	-	-	-	-	-	-	-	-	-	-
180M	-	-	-	-	-	-	-	-	-	-	-	-
180L	-	-	-	-	-	-	-	-	-	-	-	-

- NOTES:** - The motors of the IE2 efficiency class must be connected to the network by means of an inverter (Reg. 640/2009 of 22/07/2009 and the Reg. 4/2014 of 06/01/2014)
- The values given in the table refer to continuous duty S1
  - The values given are typical but not guaranteed

### 6.2.2 4-Pole standard motors with wound rotors for 50Hz and use at 50Hz

Frame Size	Rated power [kW]	Speed [rpm]	Voltage [V]	Current 400V [A]	Efficiency			Cos. $\phi$	Cn rated torque [Nm]	Cs/Cn Locked rotor torque/ rated torque	Is/In Locked rotor current/rated current	Cmax/Cn Break-down torque/rated torque
					100%	75%	50%					
80A	-	-	-	-	-	-	-	-	-	-	-	-
80B	0.75	1410	230/400	1.81	79.6	79.0	78.0	0.75	5.08	2.3	6.50	2.30
90S	1.1	1410	230/400	2.60	81.4	81.0	79.0	0.75	7.45	2.3	6.60	2.30
90L	1.5	1420	230/400	3.49	82.8	82.0	80.0	0.75	10.09	2.3	6.90	2.30
100LR	2.2	1430	230/400	4.65	84.3	84.6	84.4	0.81	14.69	2.3	7.50	2.30
100LH	3.0	1430	230/400	6.18	85.5	85.8	84.9	0.82	20.03	2.3	7.60	2.30
112M	4.0	1425	230/400	8.13	86.6	87.5	87.5	0.82	26.81	2.3	7.70	2.30
132S	5.5	1425	230/400	11.00	87.7	87.9	87.0	0.82	36.86	2.0	7.50	2.30
132M	7.5	1430	230/400	14.70	88.7	88.9	88.0	0.83	50.09	2.0	7.40	2.30
132ML	9.2	1430	230/400	18.00	89.3	89.4	88.9	0.83	61.4	2.0	7.40	2.30
160M	11	1460	400/690	21.00	89.8	90.0	89.8	0.84	71.95	2.2	7.50	2.30
160L	15	1455	400/690	28.10	90.6	91.0	90.6	0.85	98.45	2.2	7.50	2.30
180M	18.5	1470	400/690	34.00	91.2	91.4	91.1	0.86	120.19	2.2	7.70	2.30
180L	22	1470	400/690	40.30	91.6	92.0	91.6	0.86	142.93	2.2	7.80	2.30
200L	30	1470	400/690	54.60	92.3	92.6	92.2	0.86	194.90	2.2	7.20	2.30
225S	37	1470	400/690	67.00	92.7	92.7	92.0	0.86	240.37	2.2	7.30	2.30
225M	-	-	-	-	-	-	-	-	-	-	-	-
250M	-	-	-	-	-	-	-	-	-	-	-	-

- NOTES:** - The motors of the IE2 efficiency class must be connected to the network by means of an inverter (Reg. 640/2009 of 22/07/2009 and the Reg. 4/2014 of 06/01/2014)
- The values given in the table refer to continuous duty S1
  - The values given are typical but not guaranteed

**6.2.3 6-Pole standard motors with wound rotors for 50Hz and use at 50Hz**

Frame Size	Rated power [kW]	Speed [rpm]	Voltage [V]	Current 400V [A]	Efficiency			Cos. $\varphi$	Cn rated torque [Nm]	Cs/Cn Locked rotor torque/rated torque	Is/In Locked rotor current/rated current	Cmax/Cn Break-down torque/rated torque
					100%	75%	50%					
90S	-	-	-	-	-	-	-	-	-	-	-	-
90L	-	-	-	-	-	-	-	-	-	-	-	-
100LR	1.50	940	230/400	3.67	79.8	77.0	72.0	0.74	15.24	2.1	6.90	2.10
100LH	-	-	-	-	-	-	-	-	-	-	-	-
112M	-	-	-	-	-	-	-	-	-	-	-	-
132S	-	-	-	-	-	-	-	-	-	-	-	-
-	-	-	-	-	-	-	-	-	-	-	-	-
160M	-	-	-	-	-	-	-	-	-	-	-	-
160L	-	-	-	-	-	-	-	-	-	-	-	-
180M	-	-	-	-	-	-	-	-	-	-	-	-

**NOTES:** - The motors of the IE2 efficiency class must be connected to the network by means of an inverter (Reg. 640/2009 of 22/07/2009 and the Reg. 4/2014 of 06/01/2014)

- The values given in the table refer to continuous duty S1
- The values given are typical but not guaranteed

**6.2.4 2-Pole standard motors with wound rotors for 50Hz and use at 60Hz for the USA**

Rated power 50Hz [kW]	Rated power 60Hz [kW]	Speed [rpm]	Voltage [V]	Current a 460V [A]	Efficiency			Cos. $\varphi$	Cn rated torque [Nm]	Cs/Cn Locked rotor torque/rated torque	Is/In Locked rotor current/rated current	Cmax/Cn Break-down torque/rated torque
					100%	75%	50%					
0.75	0,86	3450	440-480	1.4	82.5	81.8	80.8	0.85	2.1	1.8	7.0	2.5
1.1	1.26	3450	440-480	2.1	84	83.6	81.5	0.85	3.0	1.8	7.0	2.5
1.5	1.73	3450	440-480	2.8	84	83.2	81.2	0.85	4.2	2.2	7.0	2.2
2.2	2.53	3500	440-480	3.9	87.5	87.8	87.6	0.88	6.0	1.6	7.0	2.3
3.00	3.45	3500	440-480	6.4	87.5	87.9	87.2	0.89	8.2	1.5	7.0	2.2
4.0	4.6	3500	440-480	9.3	89.5	89.7	88.8	0.9	10,9	1.5	7.0	2.0
5.5	5.5	3500	440-480	9.3	89.5	89.7	88.8	0.9	15.0	1.5	7.0	2.0
7.5	7.5	3500	440-480	12.2	89.5	89.7	88.8	0.9	20.5	1.4	7.0	2.0

**NOTES:** - The motors of the IE2 efficiency class must be connected to the network by means of an inverter (Reg. 640/2009 of 22/07/2009 and the Reg. 4/2014 of 06/01/2014)

- The values given in the table refer to continuous duty S1
- The values given are typical but not guaranteed

**6.0 IE2 MOTORS**
**6.2.5 4-Pole standard motors with wound rotors for 50Hz and use at 60Hz for the USA**

Rated power 50Hz [kW]	Rated power 60Hz [kW]	Speed [rpm]	Voltage [V]	Current a 460V [A]	Efficiency			Cos. $\varphi$	Cn rated torque [Nm]	Cs/Cn Locked rotor torque/ rated torque	Is/In Locked rotor current/ rated current	Cmax/Cn Break-down torque/ rated torque
					100%	75%	50%					
0.75	0.86	1730	440-480	1.6	82.5	81.8	80.8	0.73	4.1	2.7	6.0	3.0
1.10	1.26	1730	440-480	2.4	84	83.6	81.5	0.73	6.1	2.5	6.5	2.8
1.50	1.73	1710	440-480	3	84	83.2	81.2	0.75	8.4	2.4	5.4	2.7
2.20	2.53	1730	440-480	4	87.5	87.8	87.6	0.82	12.1	2.2	5.8	2.5
3.00	3.45	1730	440-480	6.5	87.5	87.9	87.2	0.82	16.6	1.9	5.8	2.3
4.0	4.6	1740	440-480	9	89.5	89.7	88.8	0.84	22.0	1.8	5.6	2.2
5.5	6.3	1740	440-480	9.4	89.5	89.7	88.8	0.84	30.2	1.8	5.8	2.2
7.5	8.6	1740	440-480	12.5	89.5	89.7	88.8	0.86	41.2	1.7	5.8	2.0
11.0	12.7	1750	440-480	17.7	91	91.2	91	0.87	60.0	1.6	5.8	2.0
15.0	17.25	1750	440-480	24.0	91	91.4	91	0.85	81.9	1.5	5.8	2.0
18.5	21.28	1760	440-480	29.3	92.4	92.6	92.3	0.88	100.4	1.5	5.8	2.0
22.0	25.3	1760	440-480	34.5	92.4	92.8	92.4	0.88	119.4	1.5	5.8	2.0
30.0	34.5	1770	440-480	46.7	93	93.3	92.9	0.88	161.9	1.4	5.8	2.0

**NOTES:** - The motors of the IE2 efficiency class must be connected to the network by means of an inverter (Reg. 640/2009 of 22/07/2009 and the Reg. 4/2014 of 06/01/2014)

- The values given in the table refer to continuous duty S1
- The values given are typical but not guaranteed

**6.2.6 2-Pole standard motors with wound rotors for 60Hz and use at 60Hz for the South America**

Frame Size	Rated power [kW]	Speed [rpm]	Voltage [V]	Current 380V [A]	Efficiency			Cos. $\varphi$	Cn rated torque [Nm]	Cs/Cn Locked rotor torque/ rated torque	Is/In Locked rotor current/ rated current	Cmax/Cn Break-down torque/ rated torque
					100%	75%	50%					
63A	-	-	-	-	-	-	-	-	-	-	-	-
63B	-	-	-	-	-	-	-	-	-	-	-	-
71A	-	-	-	-	-	-	-	-	-	-	-	-
71B	-	-	-	-	-	-	-	-	-	-	3473.6	-
80A	0.75	3438	220/380	1.82	75.5	77.1	74.7	0.83	2.08	1.75	6.80	2.50
80B	1.1	3462	220/380	2.44	82.5	83.1	80	0.83	3.03	1.75	7.30	2.50
90S	1.5	3462	220/380	3.23	84	83.3	82.6	0.84	4.14	1.70	7.60	2.40
90L	2.2	3474	220/380	4.6	85.5	85.9	85.4	0.85	6.05	1.60	7.80	2.30
100LR	3.0	3498	220/380	5.99	87.5	87.6	86.1	0.87	8.19	1.50	8.10	2.15
100LH	-	-	-	-	-	-	-	-	-	-	-	-
112M	4.0	3474	220/380	7.9	87.5	88	87.7	0.88	11.00	1.50	8.30	2.15
132S	5.50	3510	220/380	10.7	88.5	88.2	88.2	0.88	14.96	2	8	2.1
132M	7.50	3510	220/380	14.3	89.5	88.9	88.5	0.89	20.41	2	7.8	2.1
132L	9.2	3510	220/380	18	90.2	88.8	87.5	0.89	25.03	2	7.8	2.1
160M	11.00	3510	400/690	20.8	90.2	90.3	88.5	0.89	29.93	2	7.9	2.1
160L	15.00	3516	400/690	28.4	90.2	90.4	89.3	0.89	40.74	2	8	2.1
180M	-	-	-	-	-	-	-	-	-	-	-	-
180L	-	-	-	-	-	-	-	-	-	-	-	-

**NOTES:** - The motors of the IE2 efficiency class must be connected to the network by means of an inverter (Reg. 640/2009 of 22/07/2009 and the Reg. 4/2014 of 06/01/2014)

- The values given in the table refer to continuous duty S1
- The values given are typical but not guaranteed



**6.0 IE2 MOTORS**
**6.2.7 4-Pole standard motors with wound rotors for 60Hz and use at 60Hz for the South America**

Frame Size	Rated power [kW]	Speed [rpm]	Voltage [V]	Current 380V [A]	Efficiency			Cos. $\varphi$	Cn rated torque [Nm]	Cs/Cn Locked rotor torque/ rated torque	Is/In Locked rotor current/rated current	Cmax/Cn Break-down torque/rated torque
					100%	75%	50%					
63	-	-	-	-	-	-	-	-	-	-	-	-
71A	-	-	-	-	-	-	-	-	-	-	-	-
71B	-	-	-	-	-	-	-	-	-	-	-	-
80A	-	-	-	-	-	-	-	-	-	-	-	-
80B	0.75	1710	220/380	1.84	82.5	81.8	80.8	0.75	4.2	2.75	6.5	3
90S	1.10	1704	220/380	2.65	84	83.6	81.5	0.75	6.2	2.5	6.6	2.8
90L	1.50	1704	220/380	3.62	84	83.2	81.2	0.75	8.4	2.35	6.9	2.7
100LR	2.20	1746	220/380	4.72	87.5	87.8	87.6	0.81	12.0	2.15	7.5	2.5
100LH	3.30	1740	220/380	6.35	87.5	88	87.3	0.82	16.5	1.85	7.6	2.26
112M	4.00	1734	220/380	8.47	87.5	88.4	88.4	0.82	22.0	1.85	7.7	2.26
132S	5.50	1734	220/380	11.40	89.5	89.7	88.8	0.82	30.3	1.75	7.5	2.15
132M	7.50	1752	220/380	15.30	89.5	89.7	88.8	0.83	40.9	1.65	7.4	2
132ML	9.20	1752	220/380	18	89.5	89.7	89.1	0.84	50.2	1.65	7.4	2
160M	11.00	1746	400/690	21.90	91	91.2	91	0.84	60.2	1.6	7.5	2
160L	15.00	1746	400/690	29.50	91	91.4	91	0.85	82.0	1.5	7.5	2
180M	18.50	1764	400/690	35.4	92.4	92.6	92.3	0.86	100.2	2	7.7	2.1
180L	22.00	1764	400/690	42.1	92.4	92.8	92.4	0.86	119.1	2	7.8	2.1
200L	30.00	1764	400/690	57	93	93.3	92.9	0.86	162.4	2	7.2	2.1
225S	37.00	1764	400/690	70.3	93	93	92.3	0.86	200.3	2	7.3	2.1
225M	-	-	-	-	-	-	-	-	-	-	-	-
250M	-	-	-	-	-	-	-	-	-	-	-	-

- NOTES:** - The motors of the IE2 efficiency class must be connected to the network by means of an inverter (Reg. 640/2009 of 22/07/2009 and the Reg. 4/2014 of 06/01/2014)
- The values given in the table refer to continuous duty S1
  - The values given are typical but not guaranteed

**6.2.8 6-Pole standard motors with wound rotors for 60 Hz and use at 60 Hz for the South America**

Frame Size	Rated power [kW]	Speed [rpm]	Voltage [V]	Current 380V [A]	Efficiency			Cos. $\varphi$	Cn rated torque [Nm]	Cs/Cn Locked rotor torque/ rated torque	Is/In Locked rotor current/rated current	Cmax/Cn Break-down torque/rated torque
					100%	75%	50%					
90S	-	-	-	-	-	-	-	-	-	-	-	-
90L	-	-	-	-	-	-	-	-	-	-	-	-
100LR	1.50	1128	220/380	3.56	86.5	83.4	78.0	0.74	12.70	1.9	6.00	1.90
100LH	-	-	-	-	-	-	-	-	-	-	-	-
112M	-	-	-	-	-	-	-	-	-	-	-	-
132S	-	-	-	-	-	-	-	-	-	-	-	-
132M	-	-	-	-	-	-	-	-	-	-	-	-

- NOTES:** - The motors of the IE2 efficiency class must be connected to the network by means of an inverter (Reg. 640/2009 of 22/07/2009 and the Reg. 4/2014 of 06/01/2014)
- The values given in the table refer to continuous duty S1
  - The values given are typical but not guaranteed

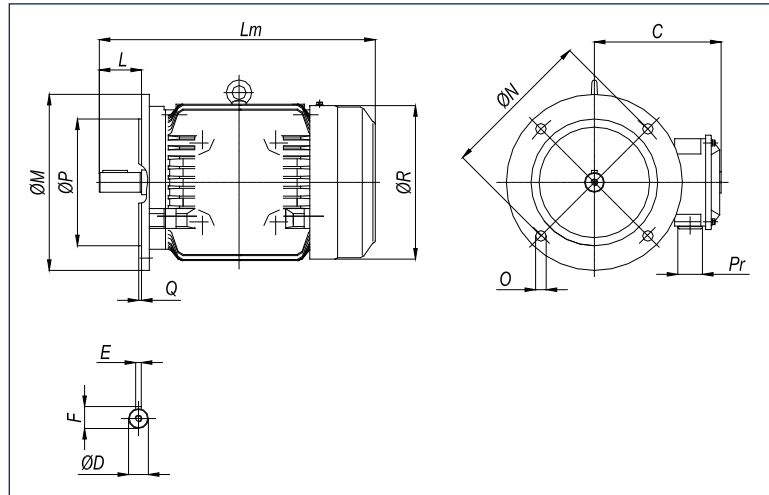
**7.1 Overall dimensions of IE3 Efficiency class WAM electric motors**
**7.1.1 B5 MOTORS (IEC)**

Power 4 P. [kW]	Size motor	C	D	E	F	L	Lm*	M	N	O		P	Q	R	Pr		Values [kg]
										Ø	n°				n°	Ø	
0.75	80B	145	19	6	21.5	40	305	200	165	12	4	130	3.5	165	1	M25 x 1,5	19
	80B (AL)																13
1.1	90S	165	24	8	27	50	355	200	165	12	4	130	3.5	190	1	M25 x 1,5	23
	90S (AL)													195			15
1.5	90L	165	24	8	27	50	385	200	165	12	4	130	3.5	190	1	M25 x 1,5	27
	90L (AL)													195			18
2.2	100LR	180	28	8	31	60	430	250	215	15	4	180	4	220	1	M25 x 1,5	36
	100LR (AL)																25
3	100LH	180	28	8	31	60	430	250	215	15	4	180	4	220	1	M25 x 1,5	40
	100LH (AL)																29
4	112M	190	28	8	31	60	470	250	215	15	4	180	4	225	2	M32 x 1.5	50
	112M (AL)													240			35
5.5	132S	210	38	10	41	80	480	300	265	15	4	230	4	275	2	M32 x 1.5	76
	132S (AL)						470										57
7.5	132 M	210	38	10	41	80	520	300	265	15	4	230	4	275	2	M32 x 1.5	81
9.2	132 ML	210	38	10	41	80	530	300	265	15	4	230	4	275	2	M32 x 1.5	88
11	160 M	255	42	12	45	110	650	350	300	19	4	250	4	335	2	M32 x 1.5	130
15	160 L	255	42	12	45	110	700	350	300	19	4	250	4	335	2	M32 x 1.5	145
18.5	180 M	280	48	14	51.5	110	730	350	300	19	4	250	4	380	2	M32 x 1.5	180
22	180 L	280	48	14	51.5	110	750	350	300	19	4	250	4	380	2	M32 x 1.5	200
30	200 L	310	55	16	59	110	780	400	350	19	4	300	5	420	2	M50 x 1.5	270
37	225 S	335	60	18	64	140	820	450	400	19	8	350	5	470	2	M50 x 1,5	300
45	225M	-	-	-	-	-	-	-	-	-	-	-	-	-	-	-	-
55	250M	-	-	-	-	-	-	-	-	-	-	-	-	-	-	-	-
75	280S	-	-	-	-	-	-	-	-	-	-	-	-	-	-	-	-

dimensions in mm

**AL** = Aluminium

**G** = Cast iron

\* = ±50 mm

The weight refers to 4-Pole motors

The junction box can be positioned on the top or on the left side, seen from the guard

Tolerance		
D ISO j6 (up to D=28mm)	E ISO h9	P ISO j6 (up to the size 180)
D ISO k6 (from D=38mm to D=48mm)		P ISO js6 (from size 225 to size 250)
D ISO m6 (from D=55mm)		P ISO j6 (from size 280 to size 315)

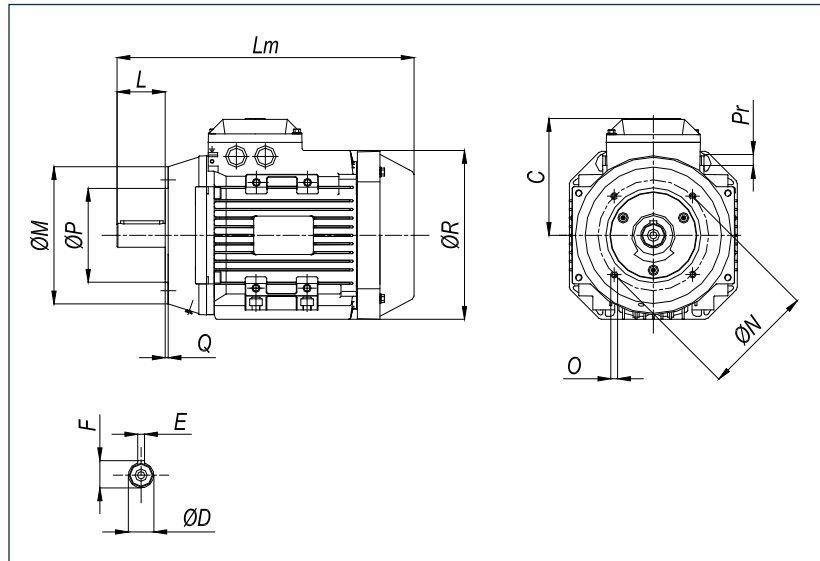
**7.1.2 B14 MOTORS (IEC)**

Power 4 P. [kW]	Size motor	C	D	E	F	L	Lm*	M	N	O		P	Q	R	Pr		Values [kg]
										Ø	n°				n°	Ø	
0.25	71A	-	-	-	-	-	-	-	-	-	-	-	-	-	-	-	-
	71A (AL)	-	-	-	-	-	-	-	-	-	-	-	-	-	-	-	-
0.37	71B	-	-	-	-	-	-	-	-	-	-	-	-	-	-	-	-
	71B (AL)	-	-	-	-	-	-	-	-	-	-	-	-	-	-	-	-
0.55	80A	-	-	-	-	-	-	-	-	-	-	-	-	-	-	-	-
	80A (AL)	-	-	-	-	-	-	-	-	-	-	-	-	-	-	-	-
0.75	80B	145	19	6	21.5	40	300	120	100	M6	4	80	3	165	1	M25 x 1,5	18.5
	80B (AL)	-	-	-	-	-	-	-	-	-	-	-	-	-	-	-	15
1.1	90S	160	24	8	27	50	350	140	115	M8	4	95	3	195	1	M25 x 1,5	25
	90S (AL)	-	-	-	-	-	-	-	-	-	-	-	-	-	-	-	17
1.5	90L	160	24	8	27	50	380	140	115	M8	4	95	3	195	1	M25 x 1,5	30
	90L (AL)	-	-	-	-	-	-	-	-	-	-	-	-	-	-	-	20
2.2	100LR	172	28	8	31	60	430	160	130	M8	4	110	3.5	220	1	M25 x 1,5	42
	100LR (AL)	-	-	-	-	-	-	-	-	-	-	-	-	-	-	-	27
3	100LH	172	28	8	31	60	430	160	130	M8	4	110	3.5	220	1	M25 x 1,5	47
	100LH (AL)	-	-	-	-	-	-	-	-	-	-	-	-	-	-	-	32
4	112M	190	28	8	31	60	465	160	130	M8	4	110	3.5	240	2	M32 x 1.5	53
	112M (AL)	-	-	-	-	-	-	-	-	-	-	-	-	-	-	-	36
5.5	132S	210	38	10	41	80	470	200	165	M10	4	130	4	275	2	M32 x 1.5	75
	132S (AL)	-	-	-	-	-	460	-	-	-	-	-	-	-	-	-	60
7.5	132M	210	38	10	41	80	510	200	165	M10	4	130	4	275	2	M32 x 1.5	78
	132M (AL)	-	-	-	-	-	500	-	-	-	-	-	-	-	-	-	65

dimensions in mm

**AL** = Aluminium

**G** = Cast iron

\* = ±50 mm

 = not available

The weight refers to 4-Pole motors

The junction box can be positioned on the top or on the left side, seen from the guard

Tolerance		
D ISO j6 (up to D=28mm)	E ISO h9	P ISO j6 (up to the size 180)
D ISO k6 (from D=38mm to D=48mm)		P ISO js6 (from size 225 to size 250)
D ISO m6 (from D=55mm)		P ISO j6 (from size 280 to size 315)

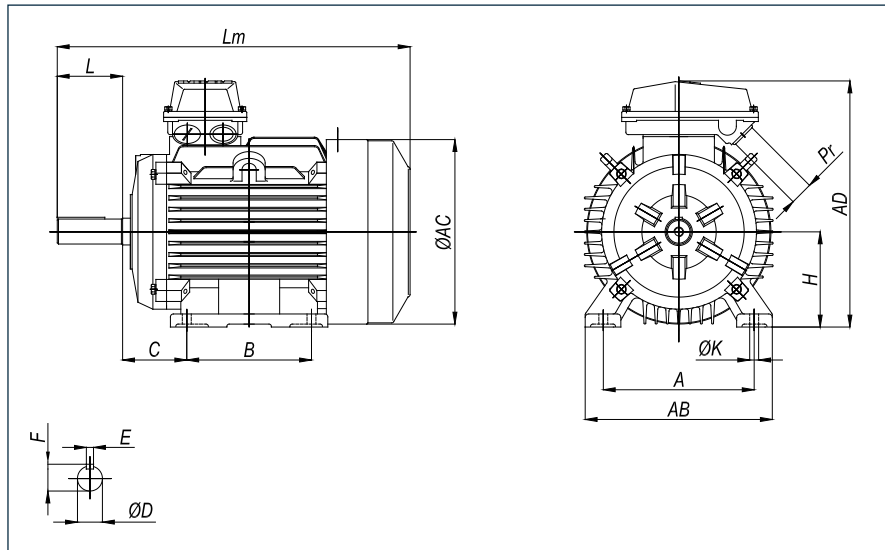
**7.1.3 B3 MOTORS (IEC)**

Power 4 P. [kW]	Size motor	A	B	C	D	E	F	H	K	L	Lm*	AB	AC	AD	Pr		Values [kg]
															n°	Ø	
5.5	132S	-	-	-	-	-	-	-	-	-	-	-	-	-	-	-	-
7.5	132M	-	-	-	-	-	-	-	-	-	-	-	-	-	-	-	-
9.2	132L	-	-	-	-	-	-	-	-	-	-	-	-	-	-	-	-
11	160 M	254	210	108	42	12	45	160	15	110	650	320	335	420	2	M32 x 1.5	135
15	160 L	254	254	108	42	12	45	160	15	110	700	320	335	420	2	M32 x 1.5	147
18.5	180 M	279	241	121	48	14	51.5	180	15	110	730	355	380	460	2	M32 x 1.5	183
22	180 L	279	279	121	48	14	51.5	180	15	110	750	355	380	460	2	M32 x 1.5	200
30	200 L	318	305	133	55	16	59	200	19	110	780	395	420	510	2	M50 x 1.5	275
37	225 S	356	286	149	60	18	64	225	19	140	820	435	470	560	2	M50 x 1.5	305
45	225M	356	311	149	60	18	64	225	19	140	840	435	470	560	2	M50 x 1.5	330
55	250M	406	349	168	65	18	69	250	24	140	985	490	535	655	2	M50 x 1.5	410
75	280S	457	368	190	75	20	79.5	280	24	140	995	550	580	700	2	M50 x 1.5	600
90	280M	457	419	190	75	20	79.5	280	24	140	1035	550	580	700	2	M50 x 1.5	640
110	315S	508	406	216	80	22	85	315	28	170	1290	635	645	845	2	M50 x 1.5	1015
132	315M	508	457	216	80	22	85	315	28	170	1330	635	645	845	2	M50 x 1.5	1110
160	315L	508	508	216	80	22	85	315	28	170	1330	635	645	845	2	M50 x 1.5	1180
200	315L2	508	508	216	80	22	85	315	28	170	1330	635	645	845	2	M50 x 1.5	1280

dimensions in mm

\* = ±50 mm

= not available

The weight refers to 4-Pole motors

The junction box can be positioned on the top or on the left side, seen from the guard

Tolerance	
A, B ISO js14	H +0 -0.5
C +0 -2	H +0 -1.0 (from size 280 up to size 315)
D ISO j6 (up to D=28mm)	
D ISO k6 (from D=38mm to D=48mm)	
D ISO m6 (from D=55mm)	
E ISO h9	

**7.0 IE3 MOTORS**
**7.2 Electro-mechanical features of IE3 Efficiency class WAM electric motors**
**7.2.1 2-Pole Standard Motors with Wound Rotors for 50Hz and Use at 50Hz**

Frame Size IEC	Rated power [kW]	Speed [rpm]	Voltage [V]	Current 380V [A]	Efficiency			Cos. $\phi$	Cn rated torque [Nm]	Cs/Cn Locked rotor torque/rated torque	Is/In Locked rotor current/rated current	Cmax/Cn Break-down torque/rated torque
					100%	75%	50%					
80A	0.75	2865	400	1.69	80.7	80.8	79.5	0.83	2.50	2.3	6.80	2.30
80B	1.1	2885	400	2.40	82.7	82.8	81.5	0.83	3.64	2.3	7.30	2.30
90S	1.5	2885	400	3.17	84.2	84.3	83.0	0.84	4.95	2.3	7.60	2.30
90L	2.2	2895	400	4.49	85.9	86.0	84.7	0.85	7.26	2.3	7.80	2.30
100LR	-	-	-	-	-	-	-	-	-	-	-	-
100LH	3	2915	400	5.88	87.1	87.2	85.8	0.87	9.83	2.3	8.10	2.30
112M	4	2895	400	7.65	88.1	88.2	86.8	0.88	13.20	2.3	8.30	2.30
132S	5.5	2925	400	10.40	89.2	89.3	87.9	0.88	17.96	2.2	8.00	2.30
132M	7.5	2925	400	13.80	90.1	90.9	89.6	0.89	24.49	2.2	7.80	2.30
132ML	9.20	2925	400	15.00	90.6	90.9	90.2	0.89	30.00	2.2	7.80	2.30
160M	11	2930	400	20.00	91.2	91.3	90.5	0.89	35.85	2.2	7.90	2.30
160L	-	-	-	-	-	-	-	-	-	-	-	-
180M	-	-	-	-	-	-	-	-	-	-	-	-

**NOTES:** - The values given in the table refer to continuous duty S1  
 - The values given are typical but not guaranteed

**7.2.2 4-Pole standard motors with wound rotors for 50Hz and use at 50Hz**

Frame Size	Rated power [kW]	Speed [rpm]	Voltage [V]	Current 400V [A]	Efficiency			Cos. $\phi$	Cn rated torque [Nm]	Cs/Cn Locked rotor torque/rated torque	Is/In Locked rotor current/rated current	Cmax/Cn Break-down torque/rated torque
					100%	75%	50%					
80A	-	-	-	-	-	-	-	-	-	-	-	-
80B	0.75	1410	230/400	1.81	82.5	82.5	80.9	0.75	5.06	2.3	6.50	2.30
90S	1.1	1410	230/400	2.60	84.1	84.1	83.5	0.75	7.45	2.3	6.60	2.30
90L	1.5	1420	230/400	3.49	85.3	85.3	84.9	0.75	10.09	2.3	6.90	2.30
100LR	2.2	1430	230/400	4.65	86.7	86.7	85.9	0.81	14.69	2.3	7.50	2.30
100LH	3.0	1430	230/400	6.18	87.7	87.7	86.9	0.82	20.03	2.3	7.60	2.30
112M	4.0	1425	230/400	8.13	88.6	88.6	88.0	0.82	26.81	2.3	7.70	2.30
132S	5.5	1425	230/400	11.00	89.6	89.6	88.9	0.82	36.86	2.0	7.50	2.30
132M	7.5	1430	230/400	14.70	90.4	90.2	89.7	0.83	50.09	2.0	7.40	2.30
132ML	9.2	1430	230/400	18.00	91.0	90.7	90.3	0.83	61.4	2.0	7.40	2.30
160M	11	1460	400/690	21.00	91.4	91.5	90.6	0.84	71.95	2.2	7.50	2.30
160L	15	1455	400/690	28.10	92.1	92.0	91.3	0.85	98.45	2.2	7.50	2.30
180M	18.5	1470	400/690	34.00	92.6	92.8	92.0	0.86	120.19	2.2	7.70	2.30
180L	22	1470	400/690	40.30	93.0	93.1	92.4	0.86	142.93	2.2	7.80	2.30
200L	30	1470	400/690	54.60	93.6	93.5	92.9	0.86	194.90	2.2	7.20	2.30
225S	37	1470	400/690	67.00	93.9	93.9	92.8	0.86	240.37	2.2	7.30	2.30
225M	-	-	-	-	-	-	-	-	-	-	-	-
250M	-	-	-	-	-	-	-	-	-	-	-	-

**NOTES:** - The values given in the table refer to continuous duty S1  
 - The values given are typical but not guaranteed

**7.0 IE3 MOTORS**
**7.2.3 6-Pole standard motors with wound rotors for 50Hz and use at 50Hz**

Frame Size	Rated power [kW]	Speed [rpm]	Voltage [V]	Current 400V [A]	Efficiency			Cos. $\phi$	Cn rated torque [Nm]	Cs/Cn Locked rotor torque/rated torque	Is/In Locked rotor current/rated current	Cmax/Cn Break-down torque/rated torque
					100%	75%	50%					
90S	-	-	-	-	-	-	-	-	-	-	-	-
90L	-	-	-	-	-	-	-	-	-	-	-	-
100LR	1.50	940	230/400	3.67	82.5	83.1	83.3	0.74	15.24	2.1	6.90	2.10
100LH	-	-	-	-	-	-	-	-	-	-	-	-
112M	-	-	-	-	-	-	-	-	-	-	-	-
132S	-	-	-	-	-	-	-	-	-	-	-	-
132M	-	-	-	-	-	-	-	-	-	-	-	-
132ML	-	-	-	-	-	-	-	-	-	-	-	-
160M	-	-	-	-	-	-	-	-	-	-	-	-

**NOTES:** - The values given in the table refer to continuous duty S1  
 - The values given are typical but not guaranteed

**7.2.4 2-Pole standard motors with wound rotors for 50Hz and use at 60Hz for the USA**

Rated power 50Hz [kW]	Rated power 60Hz [kW]	Speed [rpm]	Voltage [V]	Current 380V [A]	Efficiency			Cos. $\phi$	Cn rated torque [Nm]	Cs/Cn Locked rotor torque/rated torque	Is/In Locked rotor current/rated current	Cmax/Cn Break-down torque/rated torque
					100%	75%	50%					
0.75	0.86	3450	440-480	1.4	77.0	77.1	76.0	0.85	2.1	1.8	7.0	2.5
1.1	1.26	3450	440-480	2.1	84.0	84.1	82.9	0.85	3.0	1.8	7.0	2.5
1.5	1.73	3450	440-480	2.8	85.5	85.6	84.3	0.85	4.2	2.2	7.0	2.2
2.2	2.53	3500	440-480	3.9	86.5	86.6	85.3	0.88	6.0	1.6	7.0	2.3
3.00	3.45	3500	440-460	6.4	86.5	86.6	85.3	0.89	8.2	1.5	7.0	2.2
4.0	4.6	3500	440-480	9.3	88.5	88.6	87.3	0.9	10.9	1.5	7.0	2.0
5.5	5.5	3500	440-480	9.3	89.5	89.6	88.3	0.9	15.0	1.5	7.0	2.0
7.5	7.5	3500	440-480	12.2	90.2	90.8	89.7	0.9	20.5	1.4	7.0	2.0
9.2	9.2	3510	440-480		90.2	90.5	89.8	0.89	25.03		7.8	2.1
11.00	11	3510	440-480		91.0	91.1	90.3	0.89	29.33		7.9	2.1
15.00	15	3516	440-480		91.0	91.1	89.9	0.89	40.74		8	2.1

**NOTES:** - The values given in the table refer to continuous duty S1  
 - The values given are typical but not guaranteed

**7.0 IE3 MOTORS**
**7.2.5 4-Pole standard motors with wound rotors for 50Hz and use at 60Hz for the USA**

Rated power 50Hz [kW]	Rated power 60Hz [kW]	Speed [rpm]	Voltage [V]	Current 380V [A]	Efficiency			Cos. $\varphi$	Cn rated torque [Nm]	Cs/Cn Locked rotor torque/ rated torque	Is/In Locked rotor current/rated current	Cmax/Cn Break-down torque/rated torque
					100%	75%	50%					
0.75	0.86	1730	440-480	1.6	85.5	85.5	85.5	0.73	4.1	2.7	6.0	3.0
1.10	1.26	1730	440-480	2.4	85.5	85.5	85.5	0.73	6.1	2.5	6.5	2.8
1.50	1.73	1710	440-480	3	83.8	83.8	83.8	0.75	8.4	2.4	5.4	2.7
2.20	2.53	1730	440-480	4	86.5	86.5	86.5	0.82	12.1	2.2	5.8	2.5
3.00	3.45	1730	440-480	6.5	86.5	86.5	86.5	0.82	16.6	1.9	5.8	2.3
4.0	4.6	1740	440-480	9	84.8	84.8	84.8	0.84	22.0	1.8	5.8	2.2
5.5	6.3	1740	440-480	9.4	86.5	86.5	86.5	0.84	30.2	1.8	5.8	2.2
7.5	8.6	1740	440-480	12.5	86.5	86.5	86.5	0.86	41.2	1.7	5.8	2.0
11.0	12.7	1750	440-480	17.7	84.8	84.8	84.8	0.87	60.0	1.6	5.8	2.0
15.0	17.25	1750	440-480	24.0	89.5	89.5	89.5	0.85	81.9	1.5	5.8	2.0
18.5	21.28	1760	440-480	29.3	89.5	89.5	89.5	0.88	100.4	1.5	5.8	2.0
22.0	25.3	1760	440-480	34.5	87.8	87.8	87.8	0.88	119.4	1.5	5.8	2.0
30.0	34.5	1770	440-480	46.7	89.5	89.5	89.5	0.88	161.9	1.4	5.8	2.0

**NOTES:** - The values given in the table refer to continuous duty S1  
 - The values given are typical but not guaranteed

**7.2.6 2-Pole standard motors with wound rotors for 60Hz and use at 60Hz for the South America**

Frame Size	Rated power [kW]	Speed [rpm]	Voltage [V]	Current 380V [A]	Efficiency			Cos. $\varphi$	Cn rated torque [Nm]	Cs/Cn Locked rotor torque/ rated torque	Is/In Locked rotor current/rated current	Cmax/Cn Break-down torque/rated torque
					100%	75%	50%					
63A	-	-	-	-	-	-	-	-	-	-	-	-
63B	-	-	-	-	-	-	-	-	-	-	-	-
71A	-	-	-	-	-	-	-	-	-	-	-	-
71B	-	-	-	-	-	-	-	-	-	-	-	-
80A	0.75	3438	220/380	1.82	77.0	77.1	76.0	0.83	2.08	1.75	6.80	2.50
80B	1.1	3462	220/380	2.44	84.0	84.1	82.9	0.83	3.03	1.75	7.30	2.50
90S	1.5	3462	220/380	3.23	85.5	85.6	84.3	0.84	4.14	1.70	7.50	2.40
90L	2.2	3474	220/380	4.6	86.5	86.6	85.3	0.85	6.05	1.60	7.80	2.30
100LR	3.0	3498	220/380	5.99	86.5	86.6	85.3	0.87	8.19	1.50	8.10	2.15
100LH	-	-	-	-	-	-	-	-	-	-	-	-
112M	4.0	3474	220/380	7.9	88.5	88.6	87.3	0.88	11.00	1.50	8.30	2.15
132S	5.50	3510	220/380	10.7	89.5	89.6	88.3	0.88	14.96	2	8	2.1
132M	7.50	3510	220/380	14.3	90.2	90.8	89.7	0.89	20.41	2	7.8	2.1
132L	9.2	3510	220/380	18	90.2	90.5	89.8	0.89	25.03	2	7.8	2.1
160M	11.00	3510	400/690	20.8	91.0	91.1	90.3	0.89	29.93	2	7.9	2.1
160L	15.00	3516	400/690	28.4	91.0	91.1	89.9	0.89	40.74	2	8	2.1
180M	-	-	-	-	-	-	-	-	-	-	-	-
180L	-	-	-	-	-	-	-	-	-	-	-	-

**NOTES:** - The values given in the table refer to continuous duty S1  
 - The values given are typical but not guaranteed

**7.0 IE3 MOTORS**
**7.2.7 4-Pole standard motors with wound rotors for 60Hz and use at 60Hz for the South America**

Frame Size	Rated power [kW]	Speed [rpm]	Voltage [V]	Current 380V [A]	Efficiency			Cos. $\varphi$	Cn rated torque [Nm]	Cs/Cn Locked rotor torque/rated torque	Is/In Locked rotor current/rated current	Cmax/Cn Break-down torque/rated torque
					100%	75%	50%					
63	-	-	-	-	-	-	-	-	-	-	-	-
71A	-	-	-	-	-	-	-	-	-	-	-	-
71B	-	-	-	-	-	-	-	-	-	-	-	-
80A	-	-	-	-	-	-	-	-	-	-	-	-
80B	0.75	1710	220/380	1.84	85.5	85.5	83.8	0.75	4.2	2.75	6.5	3
90S	1.10	1704	220/380	2.65	86.5	86.5	84.8	0.75	6.2	2.5	6.6	2.8
90L	1.50	1704	220/380	3.62	86.5	86.5	84.8	0.75	8.4	2.35	6.9	2.7
100LR	2.20	1746	220/380	4.72	89.5	89.5	87.8	0.81	12.0	2.15	7.5	2.5
100LH	3.00	1740	220/380	6.35	89.5	89.5	87.7	0.82	16.5	1.85	7.6	2.26
112M	4.00	1734	220/380	8.47	89.3	89.3	87.6	0.82	22.0	1.85	7.7	2.26
132S	5.50	1734	220/380	11.40	91.7	91.4	89.6	0.82	30.3	1.75	7.5	2.15
132M	7.50	1752	220/380	15.30	91.7	91.5	90.6	0.83	40.9	1.65	7.4	2
132ML	9.20	-	220/380	-	91.7	91.4	90.9	-	-	-	-	-
160M	11.00	1746	400/690	21.90	92.4	92.5	90.0	0.84	60.2	1.6	7.5	2
160L	15.00	1746	400/690	29.50	93.0	92.9	90.4	0.85	82.0	1.5	7.5	2
180M	18.50	1764	400/690	35.4	93.6	93.8	92.0	0.86	100.2	2	7.7	2.1
180L	22.00	1764	400/690	42.1	93.6	93.7	91.9	0.86	119.1	2	7.8	2.1
200L	30.00	1764	400/690	57	94.1	94	92.1	0.86	162.4	2	7.2	2.1
225S	37.00	1764	400/690	70.3	94.5	94.5	92.6	0.86	200.3	2	7.3	2.1
225M	-	-	-	-	-	-	-	-	-	-	-	-
250M	-	-	-	-	-	-	-	-	-	-	-	-
280S	-	-	-	-	-	-	-	-	-	-	-	-

**NOTES:** - The values given in the table refer to continuous duty S1  
 - The values given are typical but not guaranteed

**7.2.8 6-Pole Standard Motors with Wound Rotors for 60Hz and Use at 60Hz for the South America**

Frame Size	Rated power [kW]	Speed [rpm]	Voltage [V]	Current 380V [A]	Efficiency			Cos. $\varphi$	Cn rated torque [Nm]	Cs/Cn Locked rotor torque/rated torque	Is/In Locked rotor current/rated current	Cmax/Cn Break-down torque/rated torque
					100%	75%	50%					
90S	-	-	-	-	-	-	-	-	-	-	-	-
90L	-	-	-	-	-	-	-	-	-	-	-	-
100LR	1.50	1128	220/380	3.56	88.5	89.2	90.0	0.74	12.70	1.9	6.00	1.90
100LH	-	-	-	-	-	-	-	-	-	-	-	-
112M	-	-	-	-	-	-	-	-	-	-	-	-
132S	-	-	-	-	-	-	-	-	-	-	-	-
132M	-	-	-	-	-	-	-	-	-	-	-	-
132ML	-	-	-	-	-	-	-	-	-	-	-	-

**NOTES:** - The values given in the table refer to continuous duty S1  
 - The values given are typical but not guaranteed



### 8.1 Other technical features

#### Rated Power-Pn:

- Is the mechanical power provided at the motor shaft at rated voltage and frequency in service S1\*.
- Rated mains voltage and frequency represent the motor power supply data.
- According to the standards CEI 2-3 and IEC 34-1 the rated voltage allows a variation of  $\pm 5\%$  without a resulting overtemperature of  $10^{\circ}\text{C}$  permitted by the insulation classes.

#### Performance:

- The performance of a three-phased asynchronous motor is the ratio between the useful mechanical power at the axis ( $P_m$ ) and the maximum electric power absorbed ( $P_e$ ) by the motor.
- Drop in performance is given by the total of mechanical losses (friction of bearings, brushes, electromagnetic losses, losses due to ventilation).

#### Moment or Torque:

- The moment or torque is the “stress” the motor can provide when powered at rated values.
- The maximum torque is the maximum stress the motor can provide in a short time.
- The static torque is that provided by the motor at startup from motor stopped.

The two tables given below list the symbols used and certain formulae for the calculation of the motor electro-mechanical features.

Description	Symbol	Unit of Measure
Rated Power	Pn	kW
Absorbed Power	Pa	kW
Mechanical Power	Pm	kW
Voltage	V	V
Current	I	A
Frequency	F	Hz
Speed	n	r.p.m.
Moment of Inertia	J	kgm <sup>2</sup>
Torque	C	Nm
Temperature	T	°C
Difference in Temperature	T	K

USEFUL FORMULAS	
<b>Absorbed Power</b>	$P_a = \frac{1.732 \times V \times I \times \cos\phi}{1000} \text{ (kW)}$
<b>Performance</b>	$\eta\% = 100 \times \frac{P_n}{P_a}$
<b>Rated power</b>	$P_n = \frac{1.732 \times V \times I \times \cos\phi \times \eta}{1000} \text{ (kW)}$
<b>Power factor</b>	$\cos\phi = \frac{P_n \times 1000}{1.732 \times V \times I \times \eta}$
<b>Absorbed Current</b>	$I = \frac{P_a}{1.732 \times V \times \cos\phi}$

#### Correlation between the network nominal voltage and permitted motor voltage

With reference to the standard parameters shown on the rating plate:

<b>Rated mains voltage</b> 230/400V 50Hz - 460V 60Hz 400/690V 50Hz - 460V 60Hz
--

<b>Rated voltage range</b> 220-240V/380-420V 50Hz - 440-480V 60Hz 380-420V/660-725V 50Hz - 440-480V 60Hz
--

The DIN IEC 60 038 standard envisages a tolerance of  $\pm 10\%$  for mains voltages 230 V, 400 V and 690 V.

## 8.2 Voltage variations

The motors designed to be used with 230/400 and 400/690 Volts power supply at 50 Hz are compliant with the requirements on yields specified by the IEC 60034-30 standard.

These motors can operate without incurring damage, even if the supply voltage varies, within the limits set by the reference standards.

These motors can, therefore, operate with 10% voltage and 5% frequency variation, with maximum combined variation of 10% and the over-temperature value set by the same reference standards.

This means that these motors can also run on old network types:

- 220/380 Volt +/- 5%
- **230/400 Volt +/-10%**
- 240/415 Volt +/- 5%
- 380/660 Volt +/- 5%
- **400/690 Volt +/-10%**
- 415/720 Volt +/- 5%

compliant to the requirements of the regulations in several countries not standardized to the Euro-voltage.

- The following table lists the effects of voltage (power supply) variation percentage on other operating parameters of the motor (speed, efficiency, power factor and operating temperature variations).
- The supply voltage must be limited accordingly to the table.

Variation of nominal voltage	Variation of parameters							
	Locked Rotor Torque	Locked rotor current	Rated Current	Slip	Speed	Efficiency	Cos. $\varphi$	Temperature
	Cs	Is	In	s		$\varphi$		
+10%	+20%	+10%	-5%	-15%	+1%	+1%	-2.5%	-3°C
-10%	-20%	-10%	+10%	+22%	-1.5%	-1.5%	+1%	+6°C

## 8.3 Operation of motors with wound rotors for 50Hz and use at 60Hz

### Variation of rated parameters with changes in supply voltage and frequency:

- The motors manufactured to operate with supply frequency of 50 Hz can also operate at a frequency of 60 Hz, but its features will change, as shown in the Table below.
- The IEC 34-1 standards allow a rated voltage variation of  $\pm 5\%$  with the maximum temperatures exceeding  $10^\circ\text{C}$  of the values permitted by the various insulation classes.

Motor with wound rotor for 50Hz	Collegto a 60 Hz	Percentage Conversion Factors						
		Pn	Speed	Cn	Cs / Cn	Cmax/Cn	In	Is / In
230 V	230 V	100	120	83	70	85	98	83
	255 V	115	120	96	95	98	100	100
400 V	380 V	100	120	83	66	80	100	80
	400 V	100	120	83	70	85	98	83
	415 V	105	120	86	78	88	100	88
	440 V	110	120	91	85	93	100	95
	460 V	115	120	96	95	98	100	100
	480 V	120	120	100	100	100	100	105

**Special WAM motors:**

All features described below and the related combinations are available, but they must be considered as customized versions of WAM electric motors: winterization, over-ventilation, self-braking motor, with condenser, with double condenser, with heater.

**8.4 Duty type**

By duty are intended the operating conditions to which the motor is subjected.

The duty types are indicated by the symbols S1.....S10 according to IEC 60034-1 part 1.

The type of duty must be verified and establish by the customer.

**S1 Continuous Duty**

- Duty implying constant load of a duration such to allow the reaching of the thermal balance.

**S2 Short Duration Duty**

- Operation at constant load for a duration shorter than that necessary to reach the thermal balance, followed by a period of inactivity of sufficient duration to allow the motor to return to ambient temperature of the cooling agent.

**S3 Intermittent Periodic Duty**

- Operation according to a series of equal cycles, each consisting of a period of operation at constant load followed by a standby period, not connected to the supply network.

The cycle implies that it has not been reached the thermal balance during operation period.

**S4 Periodic Intermittent Duty with Start Up**

- Operation according to a series of equal cycles, each consisting of a significant start time, a time of operation at constant load, followed by a standby time not connected to the supply network.

The cycle implies that it has not been reached the thermal balance during the operation period.

**S5 Periodic Intermittent Duty with Start Up and Electrical Braking**

- Operation according to a series of equal cycles, each consisting of a start time, a time of operation at constant load, a time of electric braking followed by a standby time not connected to the supply network.

The cycle implies that it has not been reached the thermal balance during the operation period.

**S6 Continuous Duty with Intermittent Load**

- Operation according to a series of equal cycles, each consisting of an operating time at constant load and an empty run time.

The cycle implies that it has not been reached the thermal balance during the operation period.

**S7 Continuous Duty with Intermittent Load and Electrical Braking**

- Operation according to a series of equal cycles, each consisting of a start up time, an operation time at constant load, and an electrical braking time.

The cycle implies that it has not been reached the thermal balance during the operation period.

**S8 Continuous Duty with Load and Speed Intermittent Variations**

- Operation according to a series of equal cycles, each consisting of a start up time, a time with a constant load at a given speed, followed by one or more stages of operation with other constant loads corresponding to different speeds.

The cycle implies that it has not been reached the thermal balance during the operation period.

**S9 Duty with Aperiodic Load and Speed Variation**

- Operation implying load and speed variation, generally aperiodically, within the allowable range. This type of duty includes repeated overloads that can greatly exceed the full load.

**S10 Service with Discrete and Constant Speed and Load Values**

- Operation consisting of a specific load number and speed (if applicable) number with discrete values; each load/speed combination is kept even for a sufficient time to reach the thermal balance of the motor.

**8.5 Variation of the nominal power depending on the operation conditions**

- The rated values indicated on the motor rating plate refer to an environmental temperature ranging from -10°C to 40°C and an altitude not exceeding 1000 m b.s.l.
- The motor performance, and thereby the power yield, may vary with the change in these two parameters, which is inversely proportional to the temperature as well as the altitude.
- This change in performance can be partly recovered with good motor ventilation.
- The change in power (in percentage) according to the environmental temperature and altitude is shown in the charts A and B.

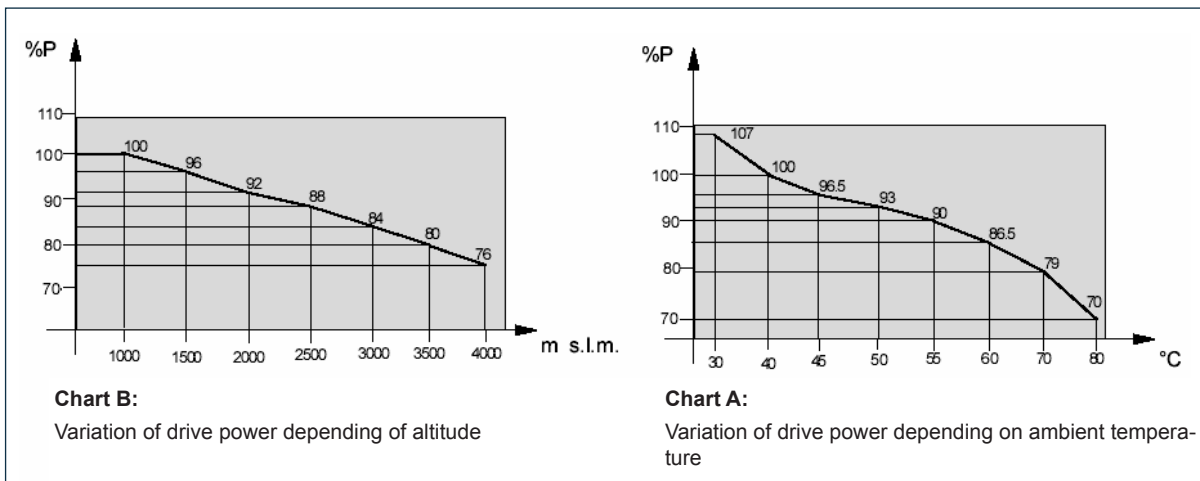

### 8.6 Insulation class

- To prevent the conductors of the electric motor winding from touching each other and cause short circuits, they have been covered with an insulating material.
- According to the IEC 60085 standard, the insulating materials are divided into insulation classes. Each class has a designation corresponding to the upper limit of the temperature reached under normal operation conditions for the insulating materials.
- According to the IEC 60034-1 Standards, the insulation class of an electric motor is identified on the basis of the insulating material used.
- The operating temperature of the motor can be checked on the basis of these classes. (See table below)

Class Insulation	Temperature threshold	$\Delta T$
<b>A</b>	105°C	60 °K
<b>E</b>	120°C	75°K
<b>B</b>	130°C	80°K
<b>F</b>	155°C	105°K
<b>H</b>	180°C	125°K

**NOTE:**  $\Delta T$  represents the difference between the temperature of the electric motor and the temperature of the environment expressed in °K (1°K=1°C)

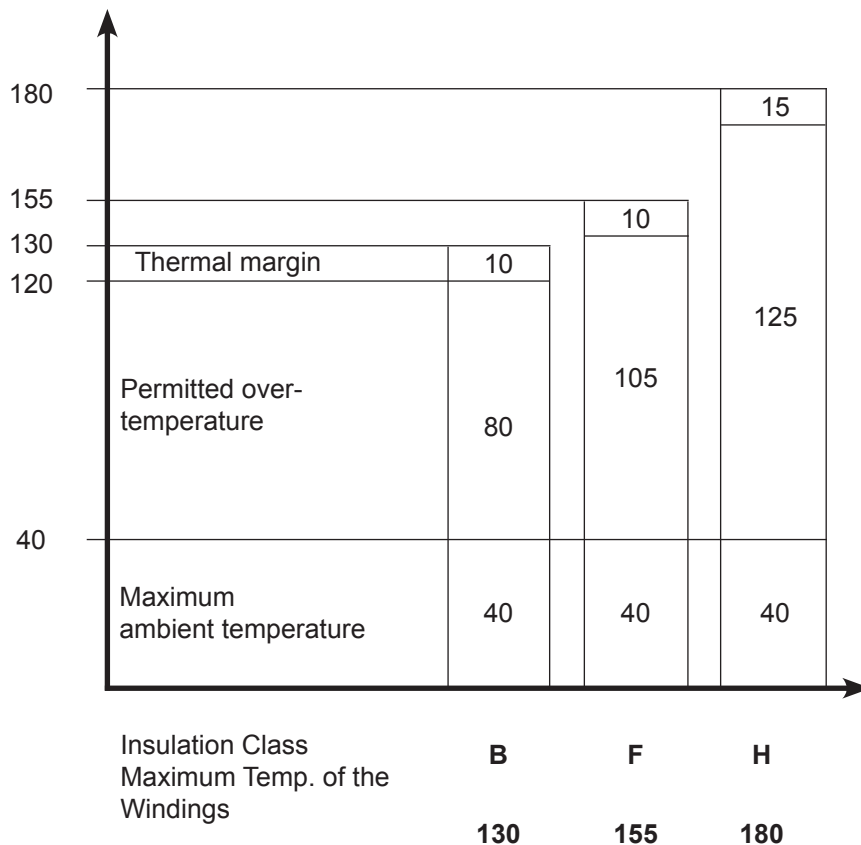

### 8.7 IP Protection degree

- The protection index is a parameter which, in accordance with IEC 34- 5 standards, is selected on the basis of the environment in which the motor is installed.
- This parameter consists of two numbers after the IP code.
- The first number indicates the degree of protection from solid bodies and the second from liquid substances.

The tables below show the type of protections for the two numbers according to the above-mentioned standards.

**IP**

Protection type		Protection type	
<b>0</b>	None	<b>0</b>	None
<b>1</b>	For intrusion of foreign matters of	$\varnothing \Rightarrow 50 \text{ mm}$	<b>1</b> For weak vertical rain
<b>2</b>		$\varnothing \Rightarrow 12 \text{ mm}$	<b>2</b> For weak rain from variable directions
<b>3</b>		$\varnothing \Rightarrow 2.5 \text{ mm}$	<b>3</b> For weak water spray
<b>4</b>		$\varnothing \Rightarrow 1 \text{ mm}$	<b>4</b> For water spray from any direction
<b>5</b>	For dust intrusion	<b>5</b>	For water jets
<b>6</b>	Total protection	<b>6</b>	For strong water jets

### 8.8 Bearings

- The ball bearings used have a double-protection shield, are pre-lubricated with grease and maintenance- free

Size	Type of bearing	No. of poles
63	6201 - 2z	
71	6202 - 2z	
80	6204 - 2z	
90	6205 - 2z	
100	6206 - 2z	
112	6306 - 2z	
132	6308 - 2z	
160	6309	
180	6311	
200	6312	
225	6313	
250	6314	
280	6314	2p
	6317	4, 6, 8p
315	6316	2p
	2319 ; 6319	4, 6, 8, 10p

### 8.9 Thermistors

All WAM® electric motors are equipped with PTC (Positive Temperature Coefficient) thermistors; their resistance increases with the general temperatur increase.

PTC thermistors, in compliance with IEC 60947-8, DIN 44081, are part of the motor protection. They are included in each phase of stator winding.

As the temperature of the winding rises the electrical resistance of the thermistor increases. This current is sent to a relay protection that cuts the power when the motor exceeds the temperature limit of the insulation material used (for WAM® motors insulation class F).

**N.B.:** The presence of PTC thermistors alone does not prevent the temperature from exceeding the limit of the motor insulation class.

To protect the motor, the thermistors have to be connected to a thermistor relay operating independently and having the function to disconnect the motor from the mains.

**NOTE:** It is possible to connect the thermistors to equipment other than the thermistor relay, such as the input of a frequency converter (check local regulations).

**8.0 TECHNICAL FEATURES**
**Technical features**

Technical features		Triple PTC	Measurement unit
Max. operating voltage	U max	30	V
Normal use voltage	V	≤ 2,5	V
Thermistor activation temperature	Tk	140	°C
Tk tolerance		± 5	°C
Tk repeatability	ΔT	± 0,5	°C
Resistance at T=25°C±1°C (V ≤ 2,5 V)	R25	≤ 300	Ω
Resistance at Tk-5°C (V ≤ 2,5 V)	Tk-5°C	≤ 1650	Ω
Resistance at Tk+5°C (V ≤ 2,5 V)	Tk+5°C	≥ 3990	Ω
Resistance at Tk+15°C (V ≤ 2,5 V)	Tk+15°C	≥ 12	kΩ
Resistance at -20°C ~ Tk-20°C (V ≤ 2,5 V)		≤ 750	Ω
Tk reaction time	Td	< 5	s
Resistenza di isolamento	V	2,5	kV

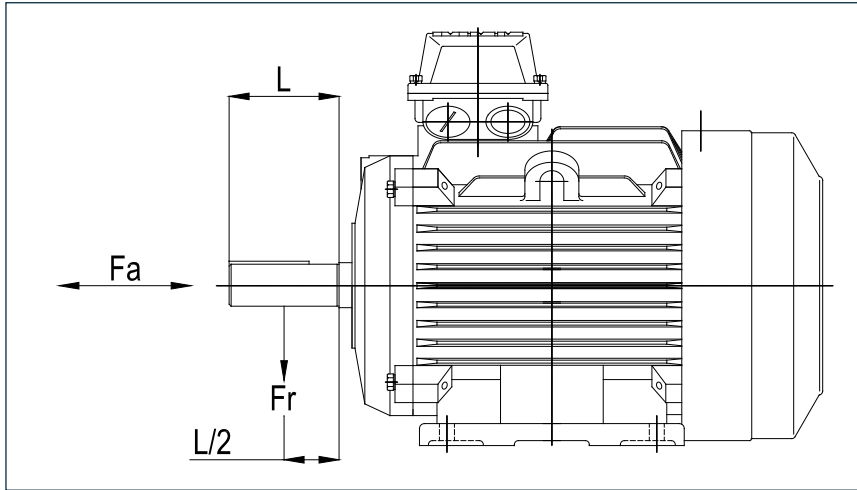

**8.10 Permitted axial and radial loads**

Frame Size	2P		4P		6P		8P	
	Fr	Fa	Fr	Fa	Fr	Fa	Fr	Fa
<b>63</b>	300	140	390	190	-	-	-	-
<b>71</b>	340	170	430	230	510	280	540	340
<b>80</b>	540	275	760	340	780	455	860	500
<b>90S</b>	590	290	825	370	850	500	940	555
<b>90L</b>	610	290	855	370	885	500	970	555
<b>100L</b>	835	380	1070	535	1200	700	1320	770
<b>112M</b>	840	480	1175	675	1210	700	1335	770
<b>132S</b>	1250	800	1750	1125	1800	1160	2000	1275
<b>132M</b>	1300	800	1800	1125	1850	1160	2050	1275
<b>160M</b>	1380	840	1930	1175	1990	1210	2195	1330
<b>160L</b>	1425	840	1995	1175	2060	1210	2265	1330
<b>180M</b>	2800	1320	2988	1955	4250	2000	4450	2090
<b>180L</b>	-	-	3073	1955	3518	2000	3881	2090
<b>200L</b>	3500	1500	4500	2000	5000	2100	5380	2300
<b>225S</b>	-	-	4800	2200	-	-	5400	2600
<b>225M</b>	3900	1600	4900	2200	5100	2300	5400	2600
<b>250M</b>	4400	1850	5800	2500	6500	2300	7000	3200
<b>280S</b>	4600	1850	6800	3000	8000	3600	8600	4000
<b>280M</b>	4700	1850	7000	3000	8200	3600	8800	4000
<b>315S</b>	5500	2200	9400	-	10600	-	10400	-
<b>315M</b>	5700	2200	9400	-	10600	-	10400	-
<b>315L</b>	5800	2200	9400	-	10600	-	10400	-

**NOTE:** The forces permitted are calculated by considering a bearings life equal to 20000 hours.

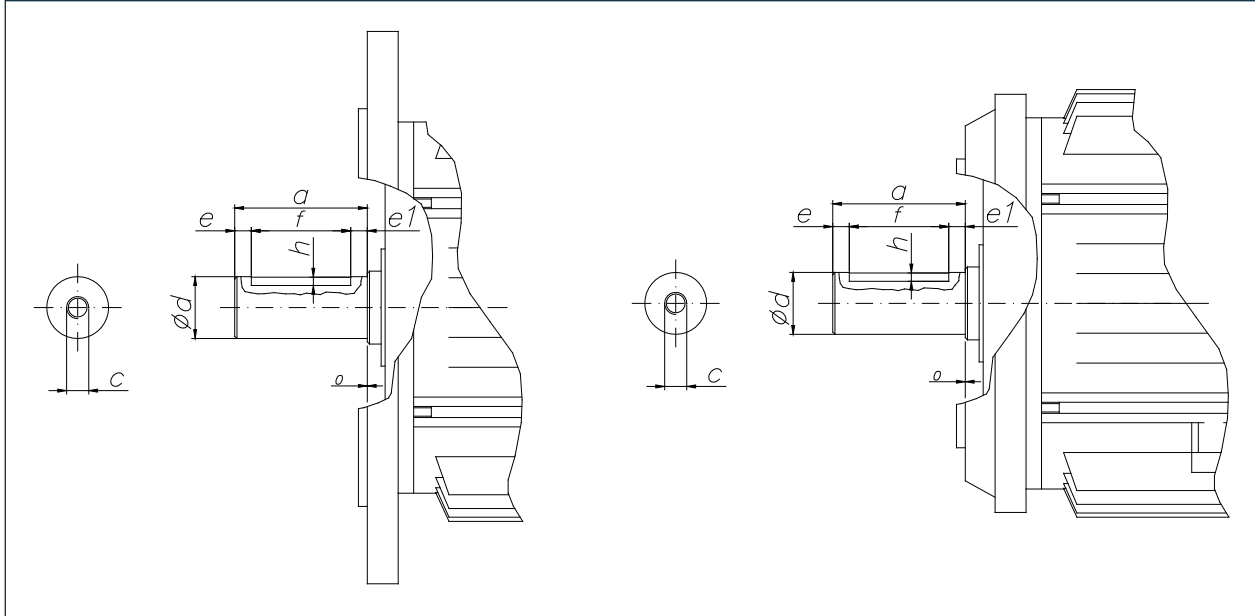
**8.11 Motor output shaft (with A-Shaped key)**

Motor size	D	A	B	C	E	F	E1	F
	j6/k6	+/-0.25	D10			+0.3/+0.2		+0.1/0
63	11	23	4	M4X12	4	15	4	2.5
71	14	30	5	M5X12	5	20	5	3
80	19	40	6	M6X16	5	30	5	3.5
90	24	50	8	M8X19	5	40	5	4
100	28	60	8	M10X22	7.5	45	7.5	4
112	28	60	8	M10X22	7.5	45	7.5	4
132	38	80	10	M12X28	10	60	10	5
160	42	110	12	M16X36	10	90	10	5
180	48	110	14	M16X35	10	90	10	5.5
200	55	110	16	M20X42	10	90	10	6
225M(2P)	55	110	16	M20X42	10	90	10	7
225M(4-8P)	60	140	18	M20X42	10	110	20	7
225S	60	140	18	M20X42	10	110	20	7
250(2P)	60	140	18	M20X42	10	110	20	7
250(4-8P)	65	140	18	M20X42	10	110	20	7
280(2P)	65	140	18	M20X42	10	110	20	7
280(4-8P)	75	140	20	M20X42	10	110	20	7.5
315(2P)	65	140	18	M20X42	10	110	20	7
315(4-8P)	80	170	22	M20X42	10	145	15	9
355(2P)	75	140	20	M20X42	10	110	20	7.5
355(4-8P)	95	170	25	M20X42	10	145	15	9

\* Unified keys and related casings in accordance with IEC 72 and DIN 6885--UNI 6604 (ex ISO 773)--Shape A

The direction of rotation of standard WAM motors is determined by observing the motor from side A (shown in Figure 1) or from the side opposite the cooling fan. The typical direction of rotation is clockwise, although the motors can rotate in both directions. To make the motor rotate in the opposite direction, or counter-clockwise, or opposite to the predefined direction, the two phase wires must be inverted.

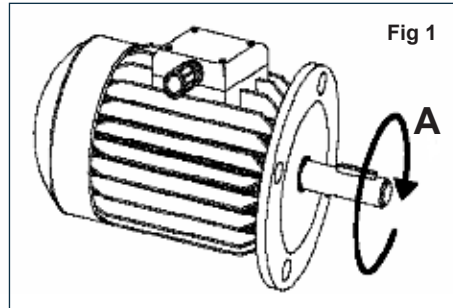

Before acting on the terminal board or electrical connections, make sure the plant is disconnected from the electric power supply. The terminal board is closed with a black polycarbonate or metal lid. The wire connection terminals are made of brass and all internal connections are made in conformity with standard IEC34-8.

**Motors with double polarity or motors controlled by inverter**

If motors with double polarity or motors controlled by inverter are used, the static torque value available is lower than the static torque delivered by a similar motor with single polarity.

**Layout of external components:**

The layout of the components outside the motor [terminal box and cable gland (1), eyebolt (2), water drain hole on fan cover (3)] is shown in the photo. The water drain hole has the same direction as the cable glands and rating plate (4) is fixed to the stator above the terminal box and in the direction opposite to the cable gland.

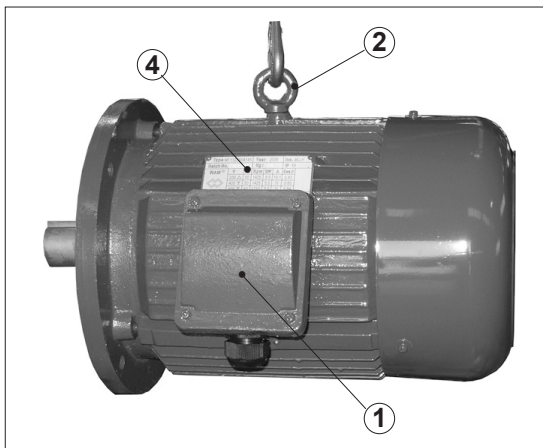

**A1 Declaration of incorporation****EU DECLARATION OF CONFORMITY**

The manufacturer:

**WAMGROUP S.p.A.**

located in

Strada degli Schiocchi, 12 - I-41124 Modena - Italy

**under its own responsibility declares that:**the electric motor series MT**complies with the requirements imposed by the following directives:**

**Directive 2014/30/EU** of the European Parliament and the Council of 26 February 2014 on the harmonisation of the laws of the Member States relating to electromagnetic compatibility;

**Directive 2014/35/EU** of the European Parliament and the Council of 26 February 2014 on the harmonisation of the laws of the Member States relating to the making available on the market of electrical equipment designed for use within certain voltage limits.

**Harmonized standards, national standards and technical regulations in question:**

UNI EN ISO 12100: 2010 ; CEI EN 60204 – 1

The signing company is committed to provide, in response to a reasoned request by national authorities, relevant information on products covered by this declaration, without prejudice to the rights of intellectual property of the manufacturer. The information will be transmitted directly to the national authorities having requested.

Strada degli Schiocchi, 12 - I-41124 Modena - Italy, July 1<sup>st</sup> 2016The person authorized to provide  
the technical documentation:

Vainer Marchesini



The legal representative:

Vainer Marchesini



WAMGROUP S.p.A. - Strada degli Schiocchi, 12 - I-41124 Modena - Italy