

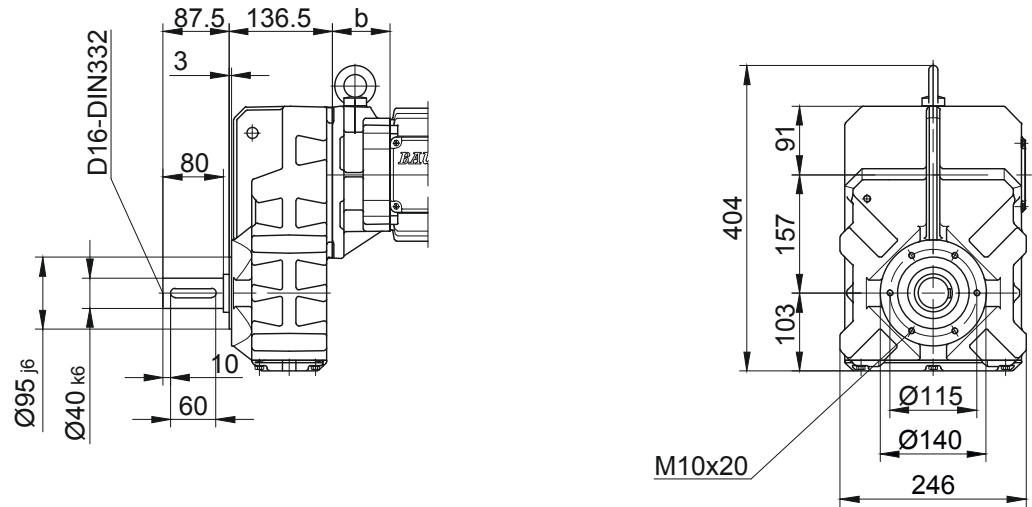

**BF30-BF30Z**

Flange with tapped holes

Code -7./



Flange with clearance holes

Code -3./

(Code -2./)

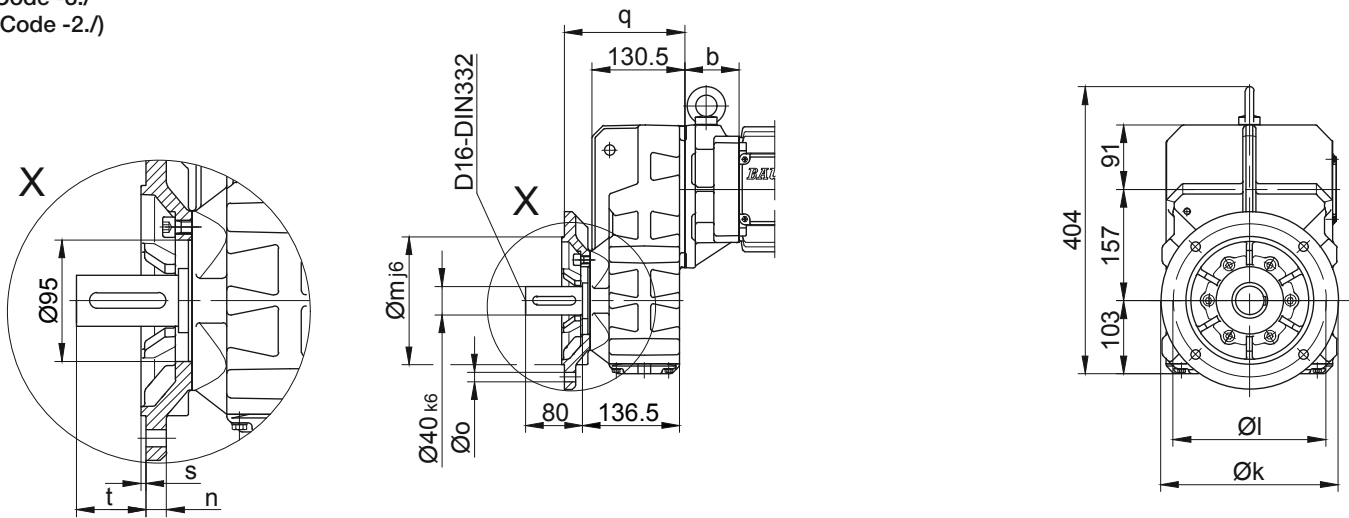

Flange Dimensions

Type	Design	k	l	m	n	o	q	s	t
BF30..	Code -3./	250	215	180	16	13.5	169.5	4	54.5
BF30..	Code -2./	200	165	130	12	11	160.5	3.5	63.5

Dimensions in millimetres (mm)

Foot with tapped holes left and right

Code -6.LR/

